

FIBER OPTIC CABLE



PT VOKSEL ELECTRIC Tbk.



Certificate ID 10630208



Certificate ID 10101456



Certificate ID 10101457



FIBER OPTIK

| | |
|---|----|
| INTRODUCTION | 1 |
| Optical Fiber Cable | 6 |
| Optical Fiber Cable ADSS Type | 8 |
| Optical Fiber Cable for Aerial Installation | 10 |
| Optical Fiber Cable for Direct Buried Installation | 12 |
| Optical Fiber Cable for Drop and Burial Cable FTTH (Fiber to the home) Installation | 14 |
| Optical Fiber Cable for Duct Installation | 16 |
| Optical Fiber Cable for Aerial and Duct (Single core per tube) Installation | 18 |



PT VOKSEL ELECTRIC Tbk.

INTRODUCTION

In the era of global telecommunication, we come to rely on light again as communication media. Optical fiber cable which opto-electronic is applied a means of transmitting in optical communication system.

This tinny thun glass fiber of approximately 10 mm in diameter could carry more information across longer distance than well-known metallic copper cable. For special purpose, a very long distance could be covered with optical fibers without any repeater.

The glass fiber consists of core and jacket which are made from very high grade pure silicon dioxide. Subject to this benefit, the fiber tensile strength s string and the light will be dopped to provide specific internal refractive index.

Optical fiber cable become more popular also in the subscriber network due to dynamic demand of communication. They are not applicable only for telephone, fax, and television but high speed computer data will be as well transferred over data highways across the entire universe.

PT. Voksel Electric Tbk, headquartered in Jakarta, is one of the indonesia's premier manufacturer of the cables used by the power generation and telecommunication industries. Since 1975 Voksel benefited from an early alliance formed with Showa Electric, Wire & Cable Co.Ltd. of Japan, through which Voksel had technical assistance, as well, as support for its own Research and Development efforts. For futher development, since 1989, that relationship became a joint venture company.

To take advantage of new marketing opportunities and to maintain its competitive edge in a fast-growing industrial sector. Voksel has vertically intergrated its operations.

The company manufacturers bare copper and aluminum conductor, low voltage and medium voltage power cables and telecommunication cables. It also

For various purpose and conditions, the optical fiber cables and designed for buried in the ground and duct, hung in air and laid down in the ocean.

Product Quality is Our Concern

PT Voksel Electric Tbk committed product quality to be the primary manner of its all facets of the company, Optical parameter is tested for all optical fiber cables covering incoming material, intermediate inspection and final inspection by applying a high quality testing equipment and operated by well-trained operators in order to meet costumer's requirement and our commitment to ISO 9000 series of Quality Management System.



manufactures copper and aluminium wire rod essential for its production of cables. Voksel committed to be the leading edge of Technology in the manufacturing and design of a wide variety of the cables.

In present, Voksel has developed his product range by manufacturing and designing optical fiber cables.

In recognition of the quality management standards in place of its manufacturing plants at Cakung (North Jakarta) and cileungsi (West Java). PT. Voksel Electric Tbk, was awarded ISO 9002 certification by SGS. Yarsley International Certification Service Ltd. In 1995.

ADVANTAGES OF OPTICAL FIBER

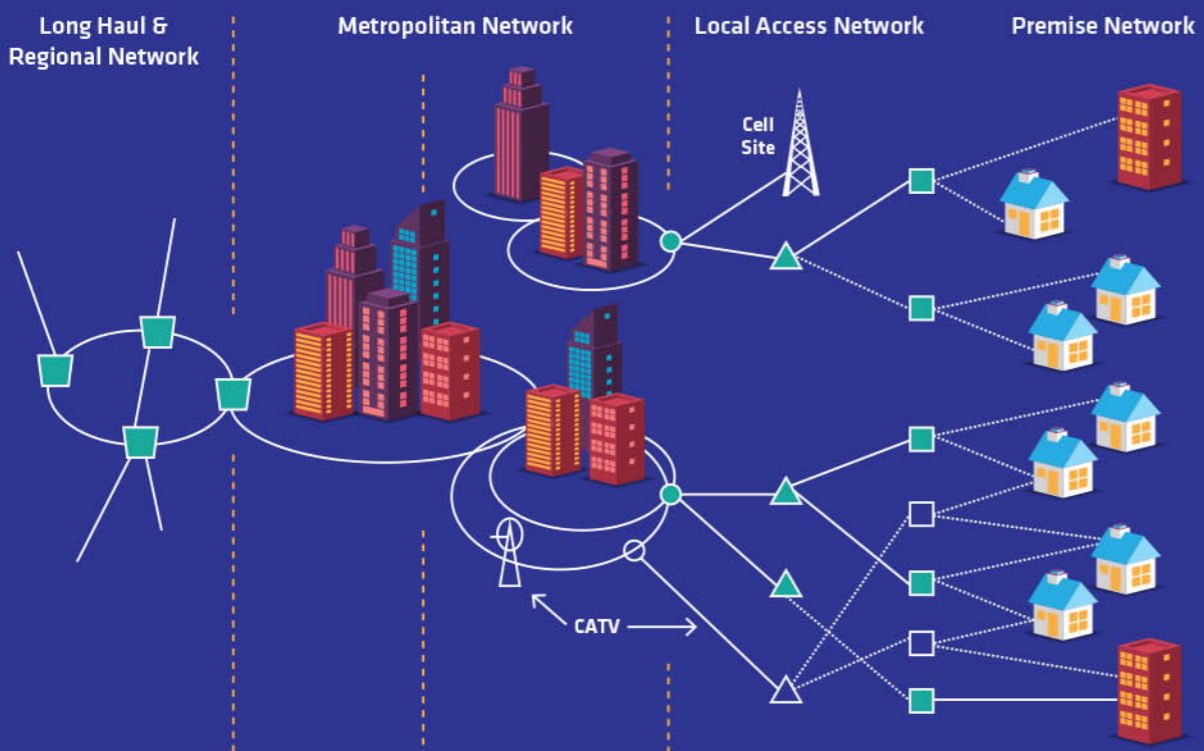
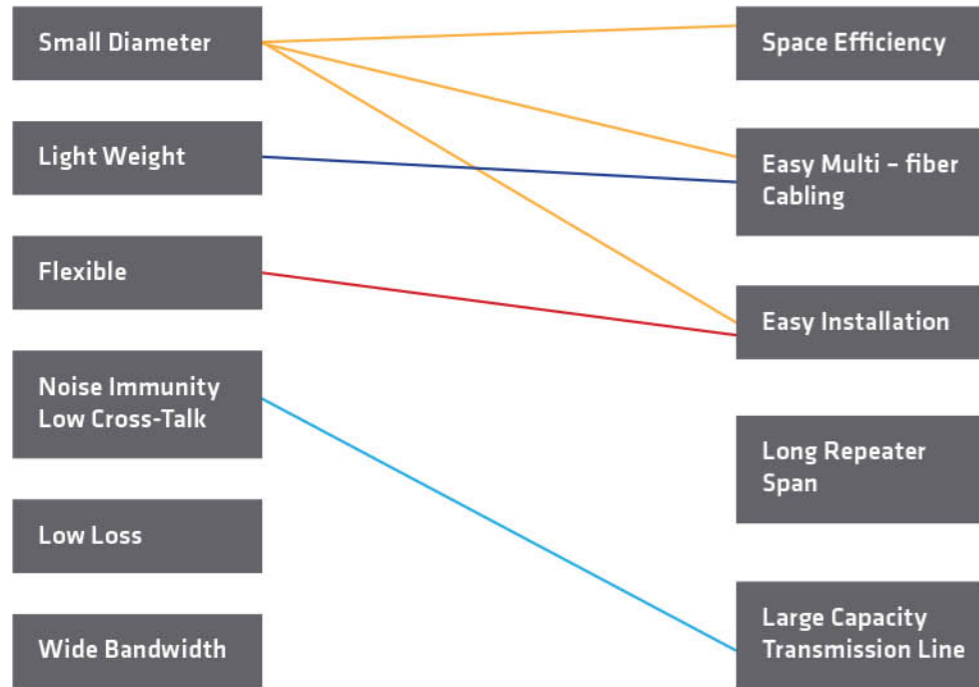

TEST EQUIPMENT

MECHANICAL TEST



■ Impact



■ Repeated Bending



■ Torsion



■ Tensile Strength



■ Crush

ELECTRICAL TEST



■ OTDR
(Optical Time Domain Reflector meter)



■ CD & PMD Test

OPTICAL FIBER CABLE

The number of fiber in a cable varies from 4 to 96 (more number of fibers are provided upon request). Optical fiber cables will generally undergo 4 processes of production line such as Coloring Line, secondary Coating Line, SZ- stranding Line and Sheathing Line.

Coloring Production Line:

Fiber Coloring Process is carried out to mark the fiber. For easy identification of individual fiber inside the tubes, they are color coded. The colors have no influence on the optical properties of the fibers. The fiber are colored using UV ink which are chosen as industry standard, easily in stripping, jointing and stability of optical loss under various stress.

SZ- Stranding Production line:

Stranding process which is tube around polyethelene coated central strength member applies with SZ- Stranding Method. The stranding is filled with jelly as Flooding Compound to fill any space of the cable to block the flow of water into the cable and jelly can change water blocking yarn to block the flow of water into the cable.

Secondary Coating Production Line:

This process uses Polybutylene Terephthalate (PBTP) as tube material which extremely has good thermal, hydrolysis and mechanical properties. The tubes contain fibers and are filled with special typical gel. Secondary coating or tubing process is used to protect the optical fibers during cabling and installation process.

Sheathing Production Line:

Sheathing line is an unit which its process protects the optical cable core from mechanical, thermal and chemical effects, associated with storage, installation and operation. The core covering is covered with laminated Aluminium Polyethelene (LAP) sheath containing carbon black, to provide an electrical ground and moisture barrier. Sheathing also uses armouring wire or tape between inner and outer sheath to provide a mechanical protection on direct buried cable. The sheath is usually over printed to identify the type of cable of a particular point.

OPTICAL FIBER DESIGN

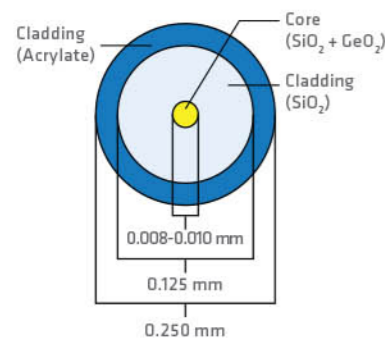

Each fiber is made of high purity Silica (SiO_2) Glass doped with Germanium (GeO_2) and fused (SiO_2) depressed cladding design for excellent geometrical properties for splicing and micro bending resistance. This fiber core is protected by two layers of UV-cured acrylate coating which is strong and durable enough to stand up to the challenge such as; micro bending losses, abrasion resistance, etc but remain easy to strip and splice.

BASIC CABLE DESIGN

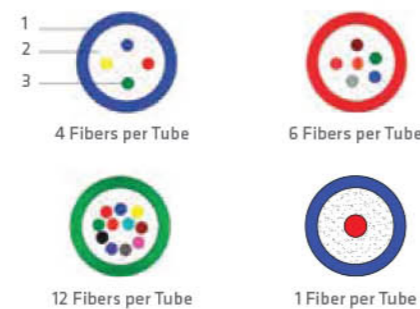

The cable core consists of stranded - six or eight thermal plastic elements with a central strength member. Elements could be either tubes, filler rods.

The coloured Polybutylene Terephthalate (PBTP) tube contains 4, 6, or 12 coloured fibers with its configuration (table 1 and 2) and water blocking compound to prevent moisture/water penetration and axial migration.

Now, there is cable core consists of stranded - twelve thermal plastic elements with a central strength member. Elements could be either tubes, filler rods, and Polybutylene Terephthalate (PBTP) tube contains 1 fibers.

THE CHARACTERISTIC OF OPTICAL FIBER CABLE

| Optical Fiber No. | Color of Fiber |
|-------------------|----------------|
| 1 | Blue |
| 2 | Orange |
| 3 | Green |
| 4 | Brown |
| 5 | Grey |
| 6 | White |
| 7 | Red |
| 8 | Black |
| 9 | Yellow |
| 10 | Violet |
| 11 | Pink |
| 12 | Turquoise |

Table 1. Color Scheme of Optical Fibers

| Tube No. | Color of Tube |
|----------|---------------|
| 1 | Blue |
| 2 | Orange |
| 3 | Green |
| 4 | Brown |
| 5 | Grey |
| 6 | White |
| 7 | Red |
| 8 | Black |
| 9 | Yellow |
| 10 | Violet |
| 11 | Pink |
| 12 | Turquoise |

Table 2. Color Scheme of PBTP Tubes

Table 3. Optical Characteristic of G.652D, G655C, G657A

| Characteristics | Unit | Value | | |
|--|--------------------------|--------------------------|--------------------------|--------------------------|
| | | G652D | G655C | G657A |
| Fiber Type | - | Single Mode | | |
| Mode Field Diameter | μm | 9.2 ± 0.4 (@1310 nm) | 9.6 ± 0.4 (@1550 nm) | 8.6 ± 0.4 (@1310 nm) |
| Mode Field Concentricity Error | μm | ≤ 0.6 | ≤ 0.8 | ≤ 0.6 |
| Cladding Diameter | μm | 125 ± 0.7 | 125 ± 0.7 | 125 ± 0.7 |
| Cladding non Circularity | % | ≤ 1 | ≤ 1 | ≤ 1 |
| Coating Diameter | μm | 250 ± 15 | 250 ± 15 | 250 ± 15 |
| Maximum Attenuation | | | | |
| @1310 | dB/km | 0.35 | - | 0.35 |
| @1550 | dB/km | 0.195 | 0.195 | 0.195 |
| @1625 | dB/km | - | 0.30 | - |
| Maximum Chromatic Dispersion | | | | |
| @1310 | ps/(nm.km) | 3.2 | - | 3.2 |
| @1530 | ps/(nm.km) | - | 1 | - |
| @1550 | ps/(nm.km) | 18 | - | 18 |
| @1565 | ps/(nm.km) | - | 10 | - |
| Min. Bending Radius | - | 20 x OD cable | 20 x OD cable | 20 x OD cable |
| Maximum Cut-off Wavelength | nm | 1260 | 1450 | 1260 |
| Zero Dispersion Wavelength (λ_0) | nm | 1300 - 1324 | 1530 - 1565 | 1300 - 1324 |
| Zero Dispersion Slope (S_0) | ps/(nm ² .km) | ≤ 0.092 | ≤ 0.092 | ≤ 0.092 |

Table 4. Environment condition

| Item | Value | Unit |
|-----------------------------|----------|--------------------|
| Operating Temperature | 10 - 50 | $^{\circ}\text{C}$ |
| Operating Relative Humidity | 20 - 100 | % |
| Storage Temperature | 10 - 70 | $^{\circ}\text{C}$ |
| Storage Relative Humidity | 20-95 | % |

OPTICAL FIBER CABLE ADSS TYPE

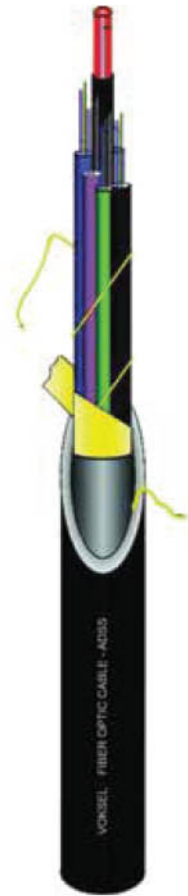

This is optical cable ADSS type (All Dielectric Self Supporting) with Aramid Yarn for peripheral strength member. This cable must have non-metallic and high tensile strength. This cable used as Aerial Application, anti rodent, anti ballistic, anti termite cable whenever mechanical strength, anti electrical induction and lighting effect. Outer jacket use PE Sheath for 110 - 120 kV, while above 120 kV use Anti Tracking PE sheath.

For Aerial Installation,
Dry Core Technology
(All Dielectric Self Supporting)

| | |
|-------------------|---|
| Fiber Type | G652 A ~ D G653 A & B G654 A ~ C G655 A ~ E |
| Cable Size | 4 ~ 264 Cores |
| Standard | ITU-T G Series IEC 60793/IEC 60794 IEC 60304 IEC 60587 Telecordia GR-20 |

TYPICAL SPECIFICATION

| Item | Number of Fiber | | | |
|--|-----------------|--------|---------|---------|
| | 4 - 16 | 6 - 36 | 24 - 72 | 60 - 96 |
| Fiber Number per Lose Tube | 4 - 6 | 6 - 12 | 6 - 12 | 12 |
| Max. Cable outer Diameter ADSS Span 100 (mm) | 12 | 14 | 14 | 16 |
| Max. Cable outer Diameter ADSS Span 400 (mm) (mm) | 13 | 15 | 16 | 19 |
| Max. Cable outer Diameter ADSS Span 600 (mm) (mm) | 13 | 15 | 16 | 19 |
| Max. Cable outer Diameter ADSS Span 900 (mm) (mm) | 15 | 16 | 18 | 22 |
| Max. Cable outer Diameter ADSS Span 1200 (mm) (mm) | 20 | 21 | - | - |

| Property | Number of Fiber | | | | Unit |
|----------------------------|-----------------|-------------|-------------|-------------|----------|
| | 4 - 16 | 6 - 36 | 24 - 72 | 60 - 96 | |
| Tensile Strength span 100 | > 3000 | > 3000 | > 3000 | > 3000 | N |
| Tensile Strength span 400 | > 11.000 | > 11.000 | > 11.000 | > 14.000 | N |
| Tensile Strength span 600 | > 15.000 | > 15.000 | > 15.000 | > 17.000 | N |
| Tensile Strength span 900 | > 24.000 | > 24.000 | > 24.000 | > 26.000 | N |
| Tensile Strength span 1200 | > 29.000 | > 29.000 | - | - | N |
| Crush Resistance | ≥ 2,2 | ≥ 2,2 | ≥ 2,2 | ≥ 2,2 | KN/100mm |
| Max. Weight span 100 | ± 110 | ± 119 | ± 145 | ± 190 | Kg/km |
| Max. Weight span 400 | ± 125 | ± 148 | ± 168 | ± 214 | Kg/km |
| Max. Weight span 600 | ± 135 | ± 159 | ± 179 | ± 225 | Kg/km |
| Max. Weight span 900 | ± 197 | ± 226 | ± 258 | ± 360 | Kg/km |
| Max. Weight span 1200 | ± 258 | ± 286 | - | - | Kg/km |
| Min. Bending span 100 | 260 | 300 | 300 | 350 | mm |
| Min. Bending span 400 | 280 | 320 | 340 | 400 | mm |
| Min. Bending span 600 | 280 | 320 | 340 | 400 | mm |
| Min. Bending span 900 | 320 | 360 | 380 | 460 | mm |
| Min. Bending span 1200 | 420 | 440 | - | - | mm |
| Temperature Storage : | - 40 to +70 | - 40 to +70 | - 40 to +70 | 40 to +70 | °C |
| Installation : | - 30 to +60 | - 30 to +60 | - 30 to +60 | - 30 to +60 | |
| Operating : | - 40 to +70 | - 40 to +70 | - 40 to +70 | - 40 to +70 | |

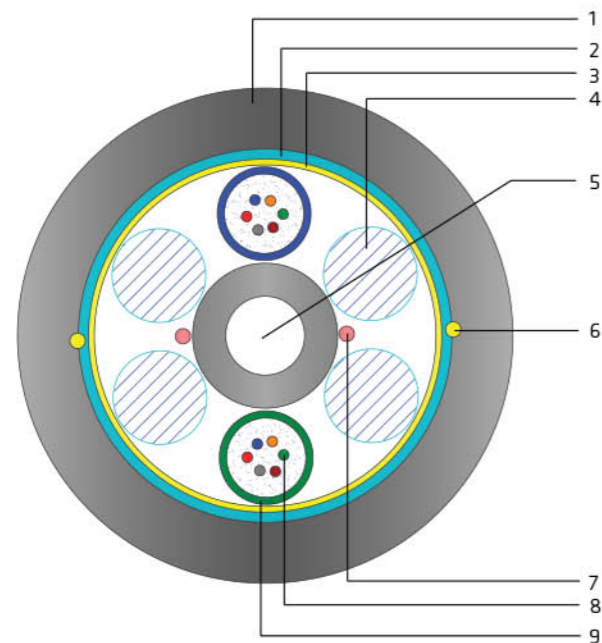

1. HDPE Anti Tracking sheath
2. Water Blocking Tape
3. Peripheral strength member (Aramid Yarn)
4. Filler Rod
5. Non Metallic Central Strength Member (GRP + PE coated)
6. Ripcord
7. Water Blocking Yarn (for dry technology) or jelly filling
8. Single mode color code optical fiber
9. Gel filed PBTP color coded tube

| Property | Value | Unit |
|-----------------|-------|------|
| Proof Test | > 0.5 | % |
| Additional Loss | < 0.1 | dB |
| Radius | 30 | mm |
| Number of Turn | 100 | - |

OPTICAL FIBER CABLE FOR AERIAL INSTALLATION



TYPICAL SPECIFICATION

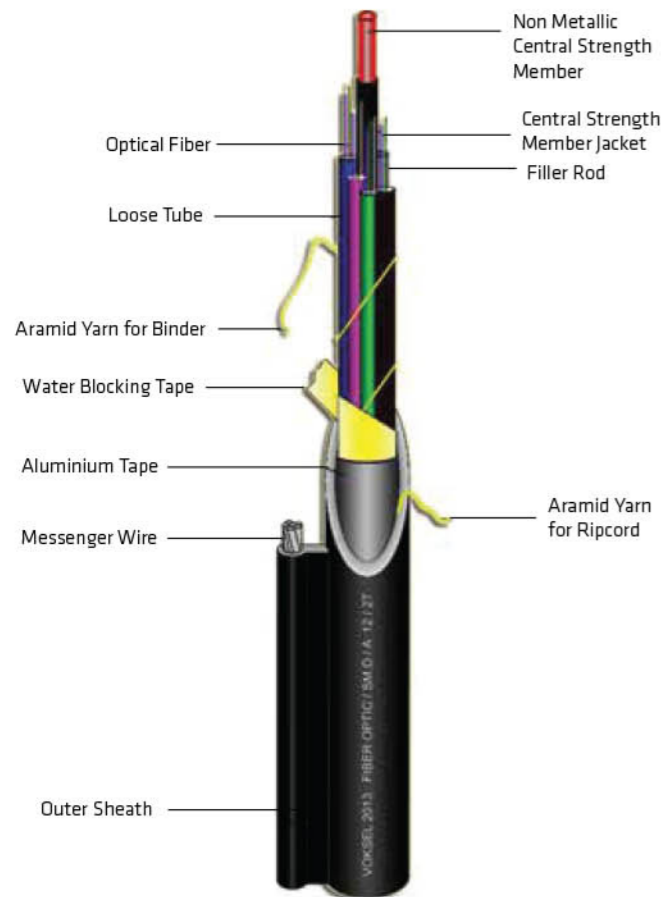

This is optical fiber cable integrated with a messenger wire for aerial installation. This cable is loose tube core, use peripheral high strength yarn as strength member and use black UV PE Sheath on outer jacket. If armoring is necessary to prevent damage by rodents, insects, and shot guns, a corrugated Steel Tape can applied.

- Fiber Type** G652 A ~ D
G653 A & B
G654 A ~ C
G655 A ~ E
- Cable Size** 4 ~ 264 Cores
- Standard** ITU-T G Series
IEC 60793/IEC 60794
IEC 60304
STEL K-017-2009 ver. 2.0

| Item | Number of Fiber | | | |
|--------------------------------|-----------------|--------|---------|---------|
| | 4 - 16 | 6 - 36 | 24 - 72 | 60 - 96 |
| Fiber Number per Loose Tube | 4 - 6 | 6 - 12 | 6 - 12 | 12 |
| Max. Cable Outer Diameter (mm) | 13 | 14 | 17 | 18 |

Mechanical Characteristic

| Property | Number of Fiber | | | | | Unit |
|-----------------------|-----------------|-------------|-------------|-------------|-------------|----------|
| | 4-16 | 18-36 | 48 | 60-72 | 84-96 | |
| Tensile strength | > 2850 | > 2850 | > 2850 | > 2850 | > 2850 | N |
| Crush Resistant | ≥ 2,2 | ≥ 2,2 | ≥ 2,2 | ≥ 2,2 | ≥ 2,2 | KN/100mm |
| Max. Weight | ± 228 | ± 310 | ± 312 | ± 320 | ± 400 | Kg/Km |
| Min. Bending | 250 | 270 | 300 | 300 | 300 | mm |
| Temperature Storage : | - 40 to +70 | - 40 to +70 | - 40 to +70 | 40 to +70 | 40 to +70 | °C |
| Installation : | - 30 to +60 | - 30 to +60 | - 30 to +60 | - 30 to +60 | - 30 to +60 | |
| Operating : | - 40 to +70 | - 40 to +70 | - 40 to +70 | - 40 to +70 | - 40 to +70 | |

| Characteristic | Value | Unit |
|-----------------|-------|------|
| Proof Test | 1 | % |
| Additional Loss | < 0.1 | dB |
| Radius | 30 | mm |
| Number of Turn | 100 | - |

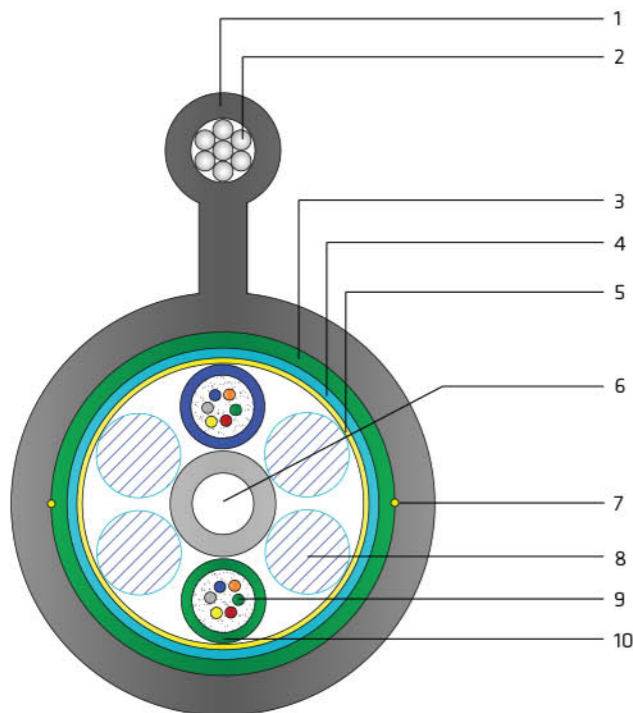

1. HDPE sheath
2. Steel wire messenger
3. Laminated Aluminum Polyethylene type
4. Water Blocking Tape
5. Peripheral strength member (Aramid Yarn).
6. Non Metallic Central Strength Member (GRP + PE coated)
7. Ripcord
8. Filler Rod
9. Single mode color code optical fiber
10. Gel filed PBTP color coded tube

OPTICAL FIBER CABLE FOR DIRECT BURIED INSTALLATION



This is optical fiber cable integrated with a corrugated steel tape, double steel tape or steel wire armoring for protection. This cable is loose tube core. This cables use loose tube core. This cable can used as direct buried, anti ballistic, anti rodent, anti termite cable whenever mechanical strength is required. If a flame retardant characteristic is required, a special material can be applied as the sheath.

For Direct Buried Installation

- Fiber Type** G652 A ~ D
G653 A & B
G654 A ~ C
G655 A ~ E
- Cable Size** 4 ~ 264 Cores
- Standard** ITU-T G Series
IEC 60793/IEC 60794
IEC 60304
STEL K-016-2009 ver. 2.0

TYPICAL SPECIFICATION

| Item | Number of Fiber | | | |
|--------------------------------|-----------------|--------|---------|---------|
| | 4 - 16 | 6 - 36 | 24 - 72 | 60 - 96 |
| Fiber Number per Loose Tube | 4 - 6 | 6 - 12 | 6 - 12 | 12 |
| Max. Cable Outer Diameter (mm) | 22 | 23 | 26 | 27 |

| Item | Number of Fiber | | | |
|--------------------------------|-----------------|-----|-----|-----|
| | 144 | 216 | 240 | 264 |
| Fiber Number per Loose Tube | 12 | 12 | 12 | 12 |
| Max. Cable Outer Diameter (mm) | 31 | 31 | 31 | 33 |

Mechanical Characteristic

| Property | Number of Fiber | | | | | Unit |
|------------------|-----------------|--------|--------|--------|--------|----------|
| | 4-16 | 18-36 | 48 | 60-72 | 84-96 | |
| Tensile Strength | > 3000 | > 3000 | > 3000 | > 3000 | > 3000 | N |
| Crush Resistance | ≥ 5,5 | ≥ 5,5 | ≥ 5,5 | ≥ 5,5 | ≥ 5,5 | KN/100mm |
| Min. Bending | 466 | 488 | 554 | 576 | 664 | mm |

| Property | Number of Fiber | | | | | Unit |
|-----------------------|-----------------|-------------|-------------|-------------|-------------|----------|
| | 120 | 144 | 216 | 240 | 264 | |
| Tensile Strength | > 3000 | > 3000 | > 3000 | > 3000 | > 3000 | N |
| Crush Resistance | ≥ 5,5 | ≥ 5,5 | ≥ 5,5 | ≥ 5,5 | ≥ 5,5 | KN/100mm |
| Min. Bending | 664 | 664 | 664 | 664 | 708 | mm |
| Temperature Storage : | - 40 to +70 | - 40 to +70 | - 40 to +70 | 40 to +70 | 40 to +70 | °C |
| Installation : | - 30 to +60 | - 30 to +60 | - 30 to +60 | - 30 to +60 | - 30 to +60 | |
| Operating : | - 40 to +70 | - 40 to +70 | - 40 to +70 | - 40 to +70 | - 40 to +70 | |

| Characteristic | Value | Unit |
|-----------------|-------|------|
| Proof Test | 1 | % |
| Additional Loss | < 0.1 | dB |
| Radius | 30 | mm |
| Number of Turn | 100 | - |

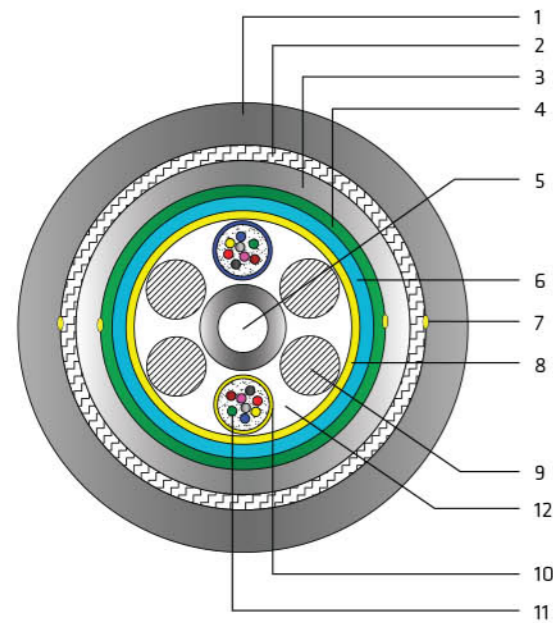

1. HDPE sheath
2. Armouring
3. MDPE inner sheath
4. Laminated Aluminum Polyethylene type
5. Non metallic central strength member (GRP+PE coated)
6. Water Blocking Tape
7. Ripcord
8. Peripheral strength member (Aramid Yarn).
9. Filler Rod
10. Gel filed PBTP color coded tube
11. Single mode color code optical fiber
12. Material Water Blocking (Jelly Compound or Water Blocking Yarn)

OPTICAL FIBER CABLE FOR DROP AND BURIAL CABLE FTTH (FIBER TO THE HOME) INSTALLATION

Drop Aerial and Burial cable being made to accommodate FTTH system telecommunication industry as for wiring from terrestrial to Ethernet system. Designed to short distance span with easy connection from end - user to nearby fiber access terminal. This cable consist of 1 up to 4 fiber core with to FRP in both inside to avoid shrieked in its cable jacketing. Cable Burial usually use in building.

CONSTRUCTION DROP AERIAL CABLE

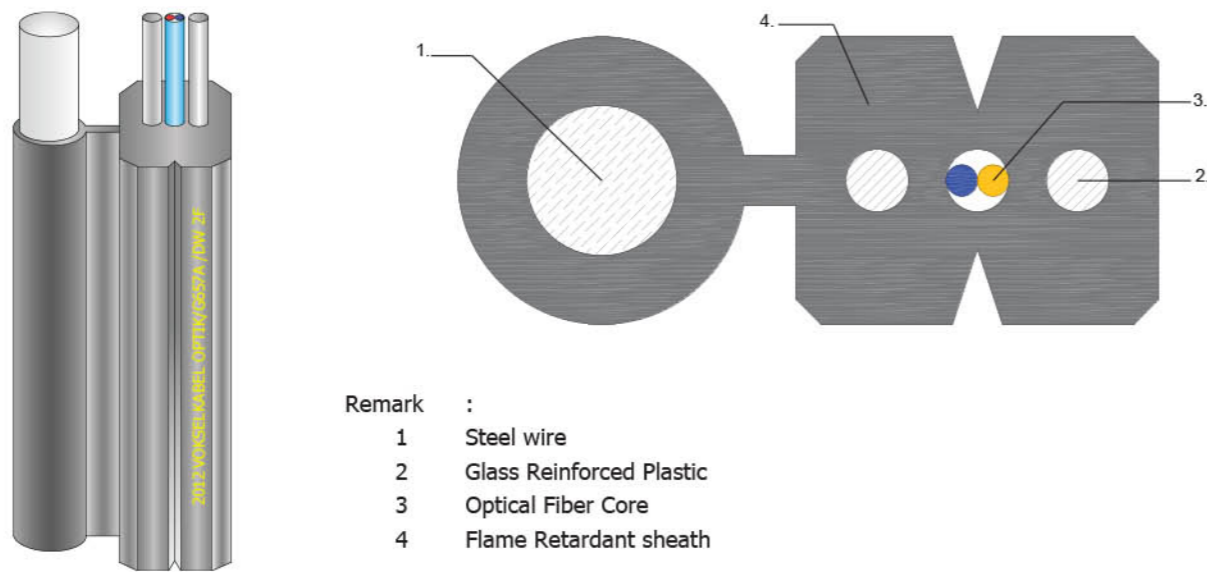

- Remark :
- 1 Steel wire
 - 2 Glass Reinforced Plastic
 - 3 Optical Fiber Core
 - 4 Flame Retardant sheath

CONSTRUCTION DROP BURIAL CABLE

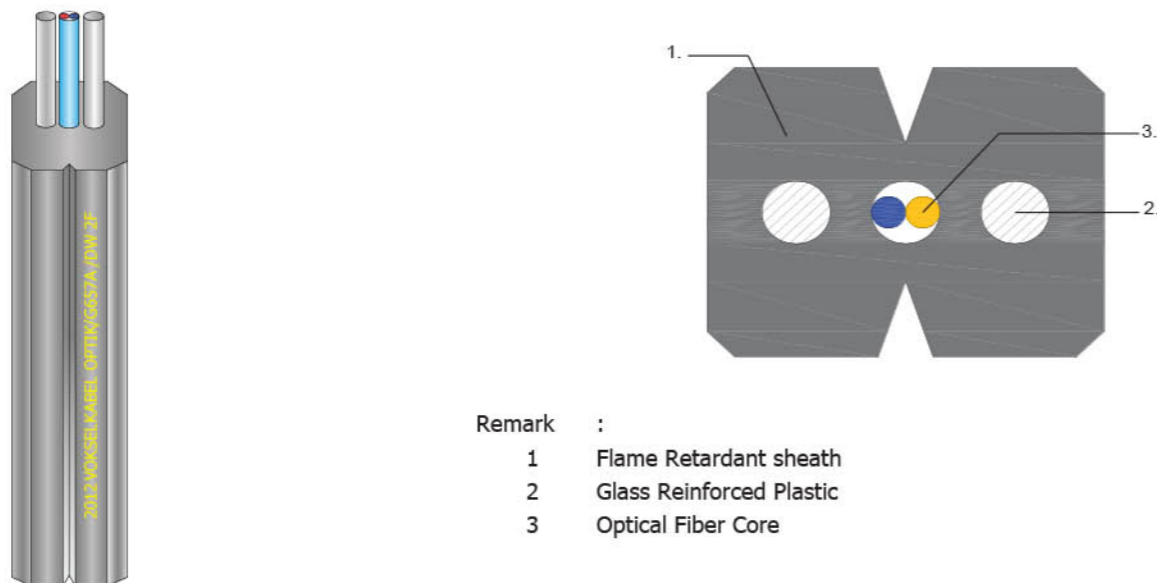

- Remark :
- 1 Flame Retardant sheath
 - 2 Glass Reinforced Plastic
 - 3 Optical Fiber Core

TYPICAL SPECIFICATION

Type Specification Drop Aerial Cable

| Item | Number of Fiber | | |
|------------------------|-----------------|---------|---------|
| | 1 | 2 | 4 |
| Max. Cable Height (mm) | 5 - 5.5 | 5 - 5.5 | 5-5.5 |
| Max. Cable Width (mm) | 2 - 2.5 | 2 - 2.5 | 2 - 2.5 |

Type Specification Single Drop Burial Cable

| Item | Number of Fiber | | |
|------------------------|-----------------|---------|---------|
| | 1 | 2 | 4 |
| Max. Cable Height (mm) | 3 - 3.5 | 3 - 3.5 | 3 - 3.5 |
| Max. Cable Width (mm) | 2 - 2.5 | 2 - 2.5 | 2 - 2.5 |

Mechanical Characteristic

| Fiber Count | Number of Fiber | | | Unit |
|------------------|-----------------|---------|---------|-------|
| | 1 | 2 | 4 | |
| Tensile Strength | > 130 | > 130 | > 130 | N |
| Crush Resistance | ≥ 0.3 | ≥ 0.3 | ≥ 0.3 | kg |
| Max. Weight | ± 10 | ± 10 | ± 38 | Kg/Km |
| Min. Bending | 20 X OD | 20 X OD | 20 X OD | mm |

| Characteristic | Value | Unit |
|-----------------|-------|------|
| Proof Test | 1 | % |
| Additional Loss | < 0.1 | dB |
| Radius | 15 | mm |

OPTICAL FIBER CABLE FOR DUCT INSTALLATION



The duct optical fiber cable is with loose tube core, it is quite suitable to the system requiring more optical cable fibers. The fibers are accommodated in jelly filled tube with an excess length.

- Fiber Type** G652 A ~ D
G653 A & B
G654 A ~ C
G655 A ~ E
- Cable Size** 4 ~ 288 Cores
- Standard** STEL QA - K - 015- 2009

TYPICAL SPECIFICATION

| Item | Number of Fiber | | | |
|--------------------------------|-----------------|--------|---------|---------|
| | 4 - 16 | 6 - 36 | 24 - 72 | 60 - 96 |
| Fiber Number per Loose Tube | 4 - 6 | 6 -12 | 6 - 12 | 12 |
| Max. Cable Outer Diameter (mm) | 13.5 | 14 | 14 | 16 |

| Item | Number of Fiber | | | |
|--------------------------------|-----------------|-----|-----|-----|
| | 144 | 216 | 264 | 288 |
| Fiber Number per Loose Tube | 12 | 12 | 12 | 12 |
| Max. Cable Outer Diameter (mm) | 22 | 22 | 22 | 24 |

Mechanical Characteristic

| Fiber Count | Number of Fiber | | | | | Unit |
|------------------|-----------------|--------|--------|--------|--------|----------|
| | 4-16 | 18-36 | 48 | 60-72 | 84-96 | |
| Tensile strength | > 2850 | > 2850 | > 2850 | > 2850 | > 2850 | N |
| Crush Resistance | ≥ 2,2 | ≥ 2,2 | ≥ 2,2 | ≥ 2,2 | ≥ 2,2 | KN/100mm |
| Max.Weight | ± 180 | ± 180 | ± 180 | ± 240 | ± 260 | Kg/Km |
| Min.Bending | 250 | 270 | 300 | 300 | 300 | mm |

| Fiber Count | Number of Fiber | | | | Unit |
|------------------|-----------------|-------------|-------------|-------------|----------|
| | 144 | 216 | 264 | 288 | |
| Tensile strength | > 2850 | > 2850 | > 2850 | > 2850 | N |
| Crush Resistance | ≥ 4,5 | ≥ 4,5 | ≥ 4,5 | ≥ 4,5 | KN/100mm |
| Max.Weight | ± 340 | ± 340 | ± 340 | ± 360 | Kg/Km |
| Min.Bending | 330 | 330 | 330 | 360 | mm |
| Temperature | | | | | °C |
| Storage : | - 40 to +70 | - 40 to +70 | - 40 to +70 | - 40 to +70 | |
| Installation : | - 30 to +60 | - 30 to +60 | - 30 to +60 | - 30 to +60 | |
| Operating | - 40 to +70 | - 40 to +70 | - 40 to +70 | - 40 to +70 | |

| Characteristic | Value | Unit |
|-----------------|-------|------|
| Proof Test | 1 | % |
| Additional Loss | < 0.1 | dB |
| Radius | 30 | mm |
| Number of Turn | 100 | - |

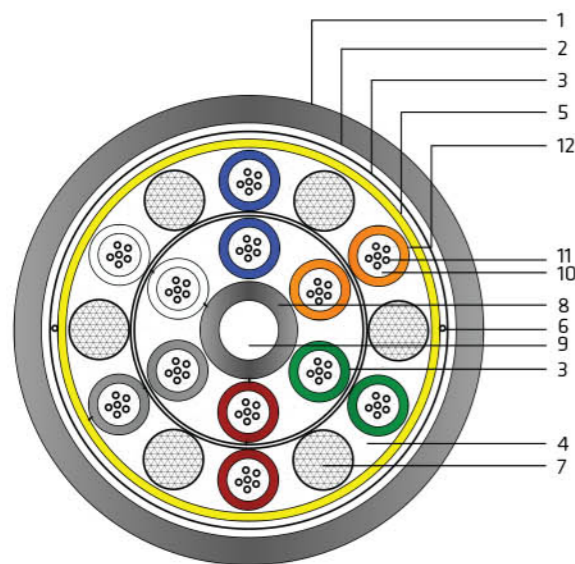

1. PE Sheath
2. Laminated Aluminium Polyethelene Tape
3. Water Blocking Tape
4. Material Water Blocking (Water Blocking Swallable Yarn or Jelly Compound)
5. Poly aramid Yarn (Optional)
6. Rip Cord
7. Filler Rod
8. PE Strength Member Jacket
9. Central Strength Member (Glass Reinforced Plastic or Steel Wire)
10. Gel Filled PBTP Color Coded Tube
11. Single Mode Coded Optical Fiber
12. PBTP Tube

OPTICAL FIBER CABLE FOR AERIAL & DUCT (SINGLE CORE PER TUBE) INSTALLATION



In fiber optic, Single Core Per Tube is one type of cable used to capture one or more optical fiber for the FTTH (Fiber to The Home) Distribution cable. With design easier to split the fiber core and connecting to termination box as well as the loose tube type is compatible in humidly temperature capacity 8 - 24 Core. There are two kind type cable FTTH (Aerial Application Cable and Duct Application Cable)

Standard Specification STEL QA - K - 036 - 2012 (AERIAL)
STEL QA - K - 037 - 2012 (DUCT)

CONSTRUCTION SINGLE CORE PER TUBE AERIAL CABLE

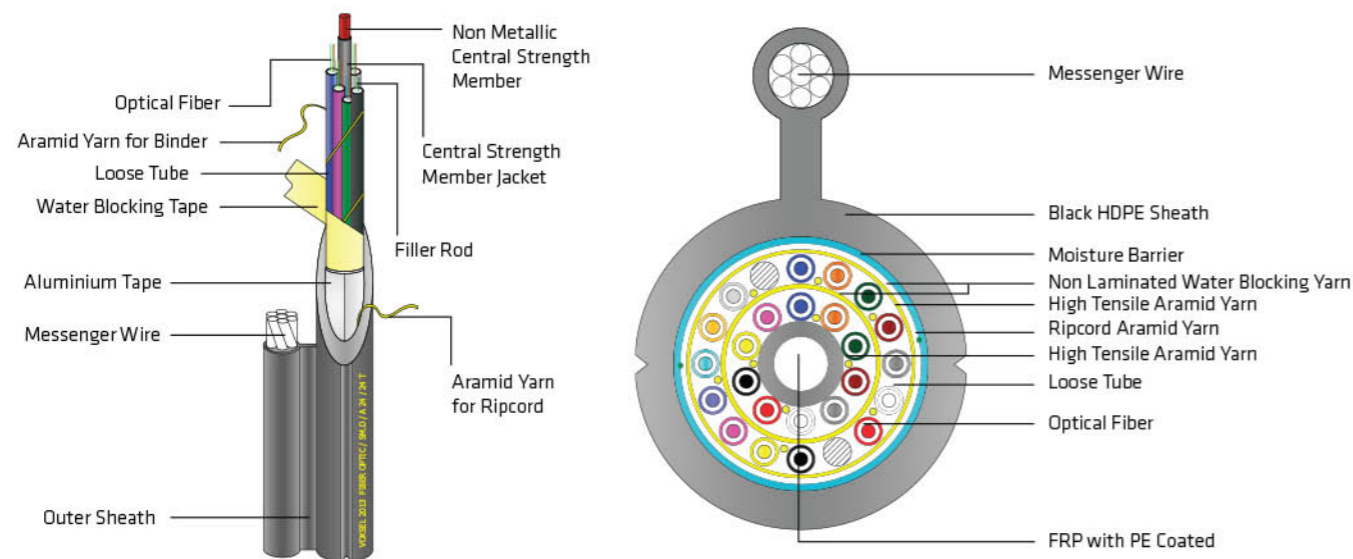

CONSTRUCTION SINGLE CORE PER TUBE DUCT CABLE

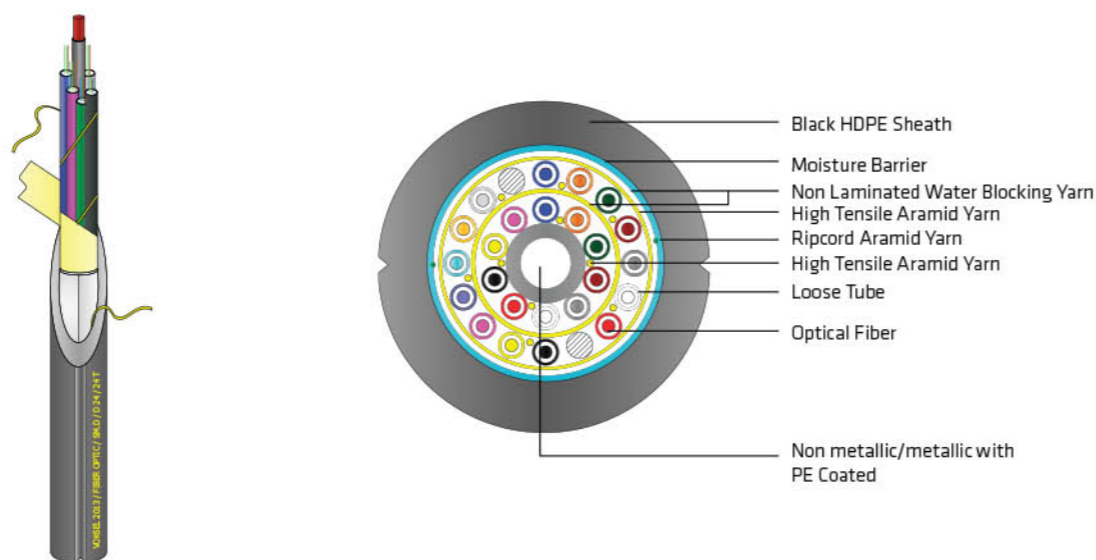

TYPICAL SPECIFICATION

Type Specification Single Core Per Tube Aerial

| Item | Number of Fiber | | | | |
|--------------------------------|-----------------|------|------|------|----|
| | 8 | 10 | 12 | 18 | 24 |
| Loose Tubes Number | 8 | 10 | 12 | 18 | 8 |
| Fiber Number per Loose Tube | 1 | 1 | 1 | 1 | 1 |
| Max. Cable Outer Diameter (mm) | 10.6 | 11.6 | 12.5 | 13.5 | 15 |

Type Specification Single Core Per Tube Duct

| Item | Number of Fiber | | | | |
|--------------------------------|-----------------|------|------|------|----|
| | 8 | 10 | 12 | 18 | 24 |
| Loose Tubes Number | 8 | 10 | 12 | 18 | 8 |
| Fiber Number per Loose Tube | 1 | 1 | 1 | 1 | 1 |
| Max. Cable Outer Diameter (mm) | 10.6 | 11.6 | 12.5 | 13.5 | 15 |

Mechanical Characteristic

| Fiber Count | Number of Fiber | | | | | Unit |
|-----------------------|-----------------|-------------|-------------|-------------|-------------|----------|
| | 8 | 10 | 12 | 18 | 24 | |
| Tensile strength | > 2850 | > 2850 | > 2850 | > 2850 | > 2850 | N |
| Crush Resistant | ≥ 2,2 | ≥ 2,2 | ≥ 2,2 | ≥ 2,2 | ≥ 2,2 | KN/100mm |
| Max. Weight | ± 185 | ± 200 | ± 210 | ± 215 | ± 240 | Kg/Km |
| Min. Bending | 20 X OD | 20 X OD | 20 X OD | 20 X OD | 20 X OD | mm |
| Temperature Storage : | - 40 to +70 | - 40 to +70 | - 40 to +70 | 40 to +70 | 40 to +70 | °C |
| Installation : | - 30 to +60 | - 30 to +60 | - 30 to +60 | - 30 to +60 | - 30 to +60 | |
| Operating : | - 40 to +70 | - 40 to +70 | - 40 to +70 | - 40 to +70 | - 40 to +70 | |

| Characteristic | Value | Unit |
|-----------------|-------|------|
| Proof Test | 1 | % |
| Additional Loss | < 0.1 | dB |
| Radius | 30 | mm |
| Number of Turn | 100 | - |

www.voksel.co.id

FIBER OPTIC CABLE



PT VOKSEL ELECTRIC Tbk.