

# RESIDENTIAL RANGE OF SPLIT AIR CONDITIONERS



## Mitsubishi Electric in INDIA

Mitsubishi Electric is a well-known brand and Global Leader in Electric and Electronic Equipment for Residential, Commercial and Industrial use. Mitsubishi Electric has presence across India with a large distribution channel which is expanding to more cities.

Mitsubishi Electric India offers complete solution for factory automation and industrial products, residential, commercial and industrial Air Conditioning, video and imaging products and provision for technical and marketing support for power semiconductors, photovoltaic modules, transportation, power systems and CNC solutions.

Mitsubishi Electric is a world leader in Air Conditioning systems for residential, commercial and industrial use. Challenged to create Air Conditioning systems that provide exemplary performance in the wide-ranging climatic conditions found throughout Japan, our engineers develop amazingly sophisticated yet durable units and systems capable of constant use under virtually any natural climatic condition on earth. Each product is an amazing feat in its own, delivering years of quiet operation, energy-efficient performance and minimum impact on the environment.

# MITSUBISHI ELECTRIC

## Residential Range of Split Air Conditioners

Page No.

**MSY-GR(T) Series**

(Tropical Inverter Cooling Only) .....



..... 05-13

**MSY-GR Series**

(Inverter Cooling Only) .....



..... 14-22

**MSY-GN Series**

(Inverter Cooling Only) .....



..... 23-29

**MSY-JS Series**

(Inverter Cooling Only) .....



..... 30-42

**KIRIGAMINE (MSY-RJS Series)**

(Inverter Cooling Only) .....



..... 43-61

**MSY-JR Series**

(Inverter Cooling Only) .....



..... 62-72

**MSZ-HP Series**

(Inverter Heat Pump) .....



..... 73-75

**MSY-JP Series**

(Inverter Cooling only) .....



..... 76-88

**MS-GK Series**

(Non-Inverter Cooling Only) .....



..... 89-93

**MS-GS Series**

(Non-Inverter Cooling Only) .....



..... 94-102

**MS-JP Series**

(Non-Inverter Cooling Only) .....



..... 103-107

# COMPLETE WARRANTY UPTO 10 YEARS



## ADDING MORE YEARS TO COMFORTABLE LIFESTYLE.

Entire range of Mitsubishi Electric Room Air Conditioners  
now comes with **WARRANTY UPTO 10 YEARS**  
with **NO HIDDEN CHARGES\***



\*T&C apply. Applicable on both Inverter & Non-Inverter Room Air Conditioners.



# GR-T Series

(Inverter Cooling Only)



*New luxurious and  
stylish design*

# Tropical Inverter Technology

Proper operation is ensured at outdoor temperatures up to 52°C with the optimized heat exchanger and the PCB's improved cooling performance. Even under harsh tropical conditions\*, this unit can maintain its rated cooling capacity and achieve comfortable air conditioning.



High cooling performance

- Keep rated capacity  
~46°C
- Guaranteed operating range  
~52°C

\* Tropical condition : Ambient temperature 46°C / 24°C, Indoor temperature 29°C / 19°C

## 01 MITSUBISHI ELECTRIC Inverter Power Module



The Inverter Power Module is the brain of the air conditioner. It minimizes power consumption by adjusting the frequency.

## 02 MITSUBISHI ELECTRIC Propeller Fan and DC Fan Motor

Propeller Fan



The newly designed propeller fan maximizes airflow efficiency. It delivers more air volume with less noise.

DC Fan Motor



A highly efficient DC fan motor drives the fan of the outdoor unit. Efficiency is much higher than an equivalent AC motor.

## 03 MITSUBISHI ELECTRIC Compressor

The compressor is the heart of the air conditioner. Employing MITSUBISHI ELECTRIC's proprietary technology, we are able to achieve both high efficiency and high power.

Poki-Poki Motor



Dramatically enhanced motor efficiency utilizing original dense winding technology

Heat Caulking

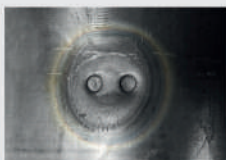

The original heat caulking method minimizes cylinder distortion for even greater efficiency.



## 04 High cooling performance even in tropical condition

Realized powerful cooling performance up to an ambient temp 46°C !

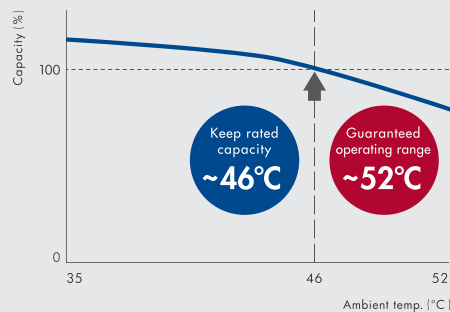

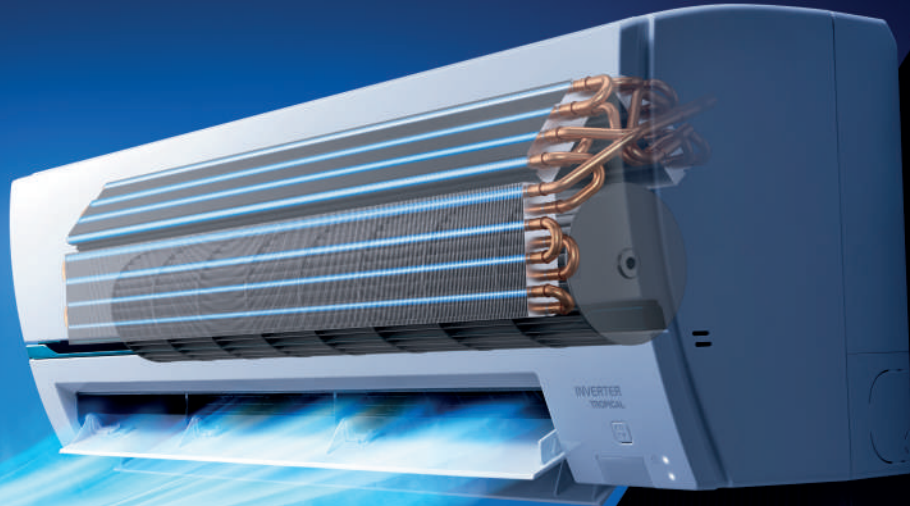

# Fast Cooling

Mitsubishi Electric, a global leader in air conditioning, understands its customer requirement better than anyone else. At Mitsubishi Electric, we invest great care in designing our product features, Instant relief from scorching heat is one such desire met successfully through the Fast Cooling feature in our air conditioners provided just at the click of a button.

## 01 Compressor Frequency image

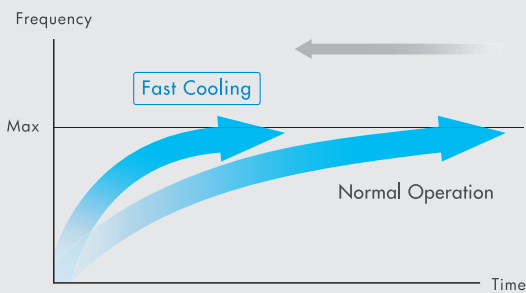

Pressing the Fast Cooling button makes the compressor reach its maximum frequency remarkably faster than in Normal Operation.

## 02 Air Outlet Temperature

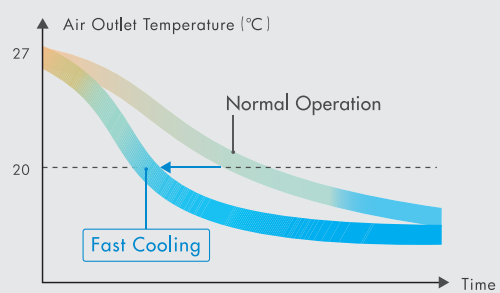

Lowers the air outlet temperature faster than Inverter Normal Operation.

## 03 Thermography

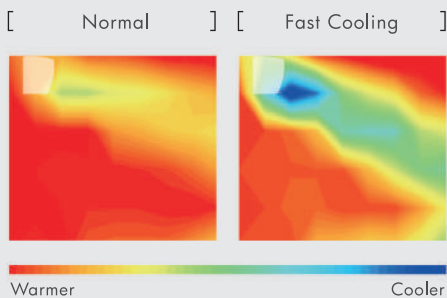

Quickly cools the room with the highest-volume, and low-temperature airflow at 2 min. after operation.

## 04 Fast Cooling button

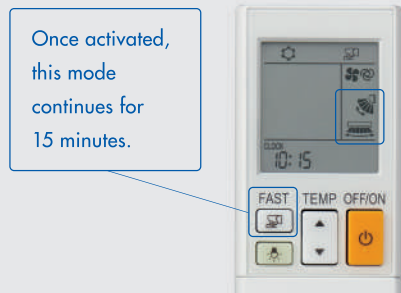

Fast Cooling mode starts immediately with the push of a button. According to preference, air direction can be changed freely.



## Long airflow

Delivers substantial and comfortable airflow

Projects air current up to 12 meters. Suitable even for living rooms.



### Model comparison

○ MSY-GR13VFT .....	8 m
○ MSY-GR18/22VFT .....	12 m

\* It's available when air direction horizontal and fan speed S-Hi.



## Auto Vane Control Up and Down/Left and Right

Auto vanes can be moved left and right, and up and down using the remote controller.

### Horizontal Airflow / Auto Vane Control

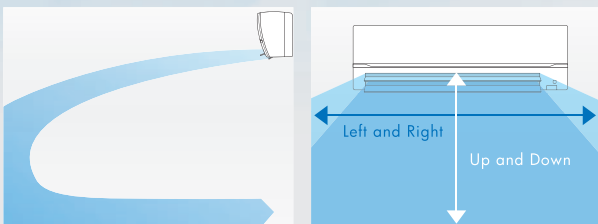

Auto Vane Control Button

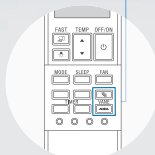

### Left & Right \*not available for MSY-GR13VFT

Auto vanes can be set at 6 position and swing.



### Up & Down

Auto vanes can be set at 5 positions and swing.



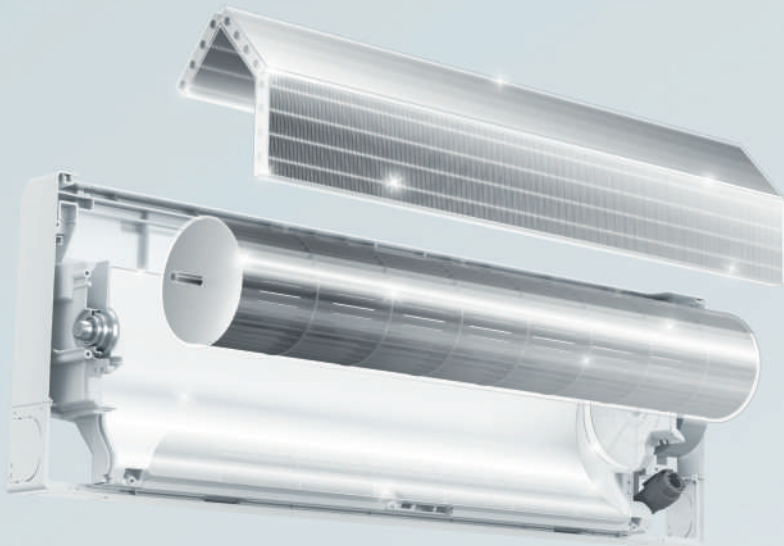

# Dual Barrier Coating

Dual Barrier Coating prevents dust and greasy dirt from getting into the air conditioner

State-of-the-art coating technology

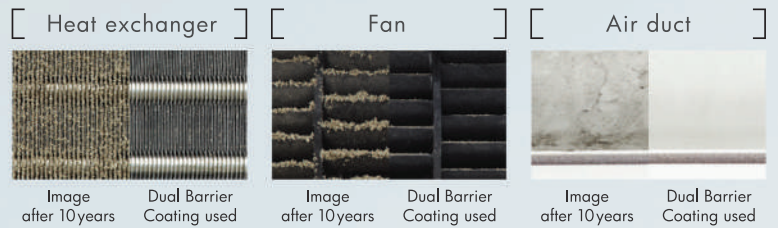
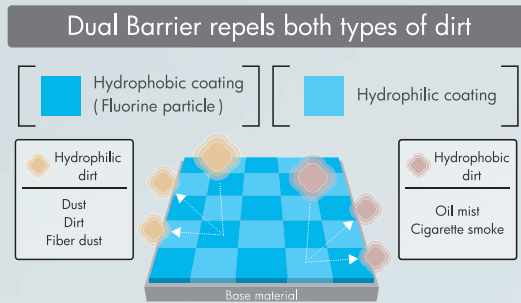

Dirt is generally classified into two groups. Dual Barrier Coating works as a two barrier coating with blended "fluorine particles" that prevent hydrophilic dirt penetration and "hydrophilic particles" that prevent hydrophobic dirt.

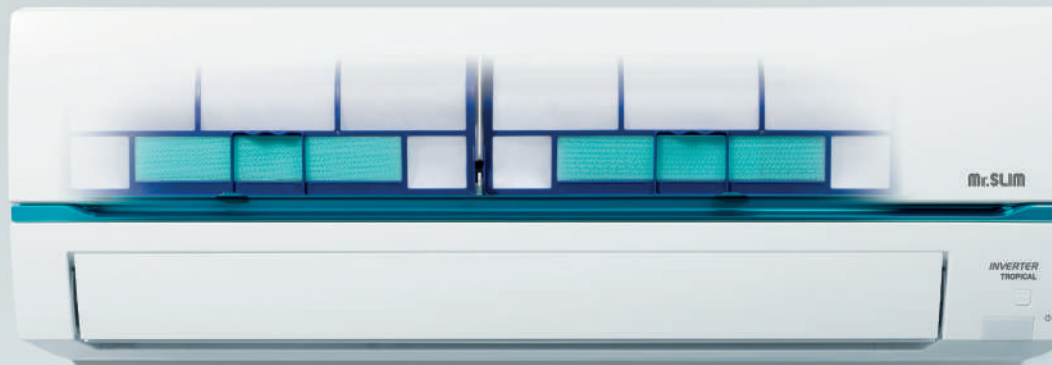

## Micro Particle Catching Filter (Standard) and High Density Filter (Optional)

Effectively eliminate PM 2.5 and catch smaller dusts.

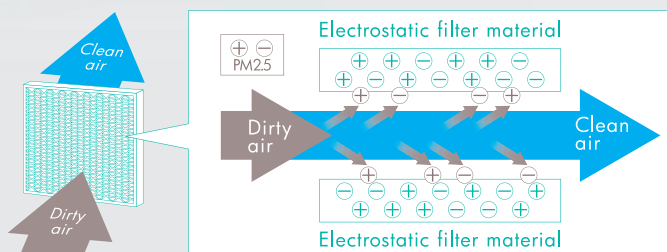

[Comparison of Density of filters]

High Density Filter can prevent smaller dust from entering the inside of air conditioners.

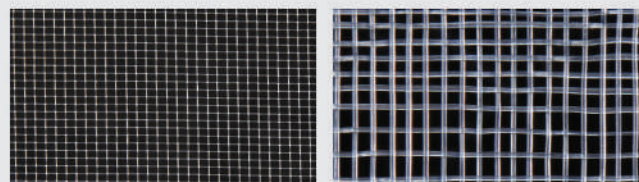



# Quiet Operation

The indoor unit level is as low as 19 dB (A) offering a peaceful indoor environment.

(Model GRT13)

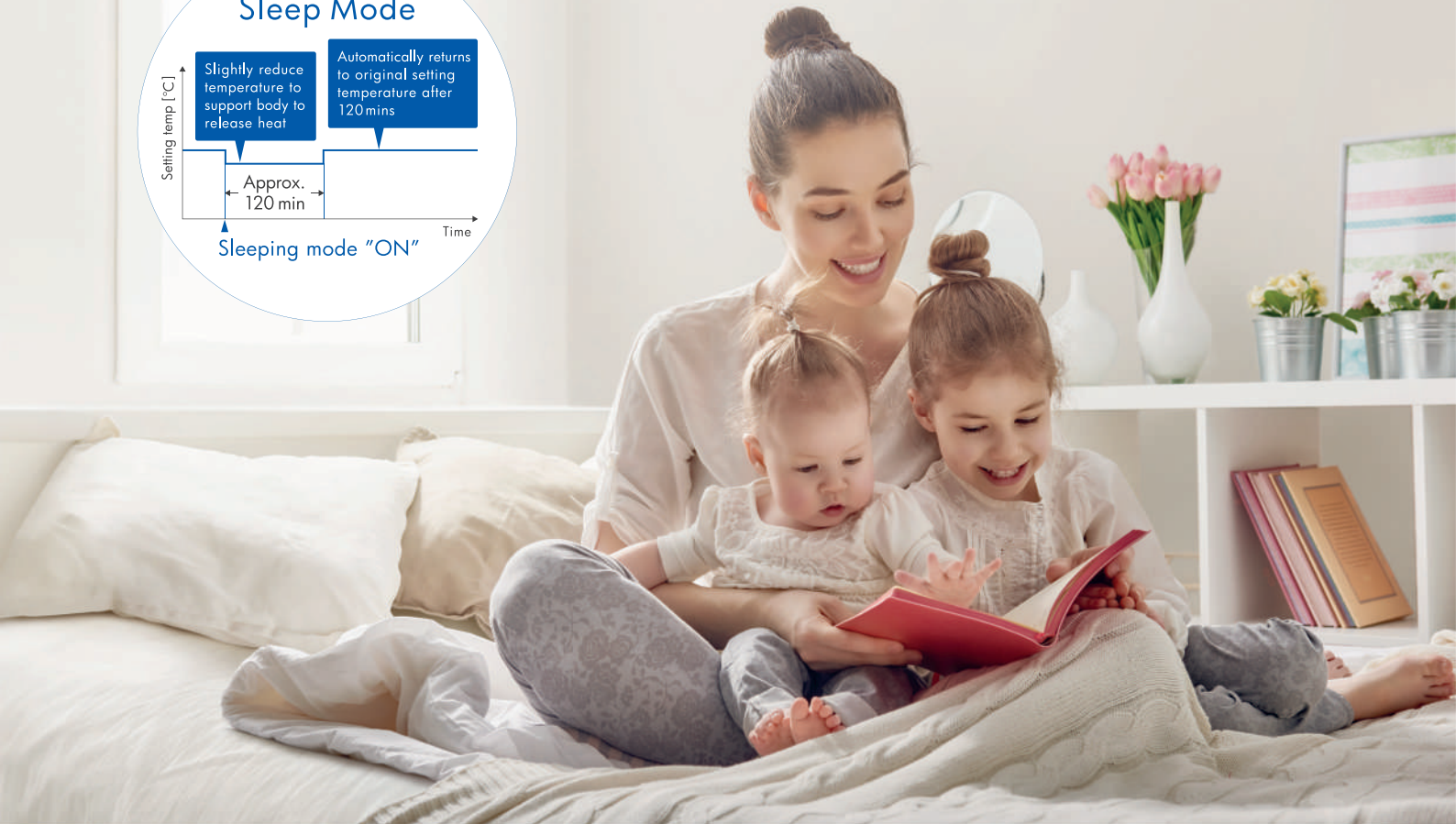
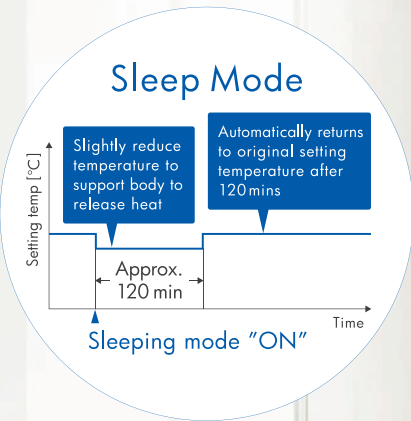

# Aerodynamics Technology

key factors to realize quiet air conditioners

## Cross-Flow-Fan



Our unique Cross Flow Fan construction guides air smoothly along each rotating blade as it simultaneously takes in and expels air. This allows for highly efficient delivery of powerful and refreshing airflow.

## Optimized aero design

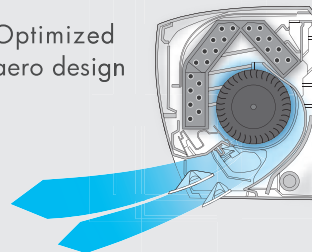

Optimized aero design utilizing 2 horizontal vanes and fixing suitable position of lower vane.



# New Remote Controller

New stylish and compact remote controller features easy-read big display and simple button position with fundamental functions.



## LED Backlight with luminous button

Once the luminous backlight button is pressed, the setting can be easily checked in the dark.



## Simple and intuitive buttons



## Error code display

Error codes are displayed on the remote controller for trouble shooting.



\* For the details, please refer to the operating Instructions

## A Remote Controller That Fits You

Its compact design creates the perfect fit for your hand.



# GR(T) Series

## Indoor Unit

GR13VFT



| H280 x W838 x D229 (mm) |

GR18/22VFT

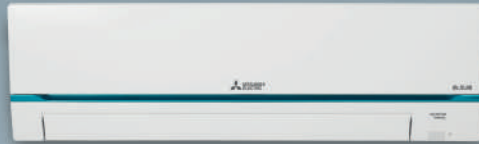

| H325 x W1100 x D257 (mm) |

[ Remote Controller ]



## Outdoor Unit

GR13VFT





























| H538 x W699 x D249 (mm) |

GR18/22VFT





| H714 x W800 x D285 (mm) |

## Functions and Features

	Joint Lap DC Motor		Magnetic Flux Vector Sine Wave Drive		Reluctant DC Rotary Compressor		Heat Caulking Fixing Method
	Vector Wave Eco Inverter		PAM (Basic)		Anti-Mold filter		High Density filter (Optional part)
	Micro Particle Catching Filter		Electrostatic Anti-allergy Enzyme Filter (Optional part)		Dual Barrier Coating		Horizontal vane swing
	Vertical vane swing		Auto vane control (Left & Right, Up & Down)		Double Horizontal vane		Auto Fan Speed Mode
	Long Airflow * GR18/22VFT		LED Back Light with Luminous button		Fast Cooling Mode		Sleep Mode
	24-Hour On/Off programmable timer		Auto Restart		Error Code display on Remote Controller		Blue Fin for Outdoorcondenser (Corrosion toughness)
	Grooved Piping		Guaranteed Ambient Operating Range up to 52°C		Keep Rated Capacity up to Ambient temp, 46°C		

## Specifications - GR(T) Series

Type			Cooling only		
Model name	Indoor unit		MSY-GR13VFT-DA1	MSY-GR18VFT-DA1	MSY-GR22VFT-DA1
	Outdoor unit		MUY-GR13VFT-DA1	MUY-GR18VFT-DA1	MUY-GR22VFT-DA1
Refrigerant			R32		
Power supply	Source		Single phase 230V, 50Hz		
			Outdoor power supply		
Capacity	Rated (Min-Max)	kW	3.7 (1.4-4.1)	5.2 (1.8-6.0)	6.6 (1.8-7.2)
	TR	TR	1.00	1.50	1.90
Total Input	Rated (Min-Max)	kW	1.01 (0.32-1.31)	1.36 (0.33-1.53)	1.72 (0.33-2.15)
ISEER			5.02	5.00	5.00
SPL	Indoor unit (Silent-Low-Med-High-Silent)	dB(A)	19-24-31-38-43	27-33-38-44-49	28-36-41-45-51
Air Volume	Indoor unit (Silent-Low-Med-High-Silent)	CFM	152-187-254-335-448	318-396-466-554-717	339-424-512-597-784
Operating Current			4.8	6.2	7.6
Indoor unit	Dimensions (H x W x D)	mm	280*838*229	325*1100*257	325*1100*257
	Weight	kg	10	17	17
Outdoor unit	Dimensions (H x W x D)	mm	538*699*249	714*800*285	714*800*285
	Weight	kg	24.5	38	38
Ext.Piping	Diameter Liquid	mm (inches)	6.35(1/4)	6.35(1/4)	6.35(1/4)
	Diameter Gas	mm (inches)	9.52(3/8)	12.7(1/2)	15.88(5/8)
	Max.Length Out-In	m	20	30	30
	Max.Height Out-In	m	12	15	15
Star Rating					
Pre filter			ANTI-MOLD		
Air cleaning filter			Microparticle catching filter(PM2.5)(STD), Electrostatic Anti Allergy Enzyme Filter(OPT)		
Timer			24h	24h	24h
Vertical Swing			o	o	o
Control wiring (Copper)	ODU to IDU	Core No. x Sq.mm	4C x 1.0	4C x 1.0	4C x 1.0
Power cable (Copper)	To ODU	Core No. x Sq.mm	3C x 1.0	3C x 2.0	3C x 2.0
ODU Breaker Size	To ODU	A	10	16	16



# GR Series

(Inverter Cooling Only)



---

New luxurious and  
stylish design

---

# All MITSUBISHI ELECTRIC Inverter Technology

The GR Series features advanced inverters that utilize MITSUBISHI ELECTRIC's cutting edge technology, developed worldwide through many years of experience. We have achieved powerful cooling with high energy efficiency, to bring you optimal comfort.



## 01 MITSUBISHI ELECTRIC Inverter Power Module



The Inverter Power Module is the brain of the air conditioner. It minimizes power consumption by adjusting the frequency.

## 02 MITSUBISHI ELECTRIC Propeller Fan and DC Fan Motor

Propeller Fan



The newly designed propeller fan maximizes airflow efficiency. It delivers more air volume with less noise.

DC Fan Motor



A highly efficient DC fan motor drives the fan of the outdoor unit. Efficiency is much higher than an equivalent AC motor.

## 03 MITSUBISHI ELECTRIC Compressor

The compressor is the heart of the air conditioner. Employing MITSUBISHI ELECTRIC's own technology, we are able to achieve both high efficiency and high power.

Poki-Poki Motor



Dramatically enhanced motor efficiency utilizing original dense winding technology

Heat Caulking



The original heat caulking method minimizes cylinder distortion for even greater efficiency.



# Fast Cooling

Mitsubishi Electric, a global leader in air conditioning, understands its customer requirement better than anyone else.

At Mitsubishi Electric, we invest great care in designing our product features. Instant relief from scorching heat is one such desire met successfully through the Fast Cooling feature in our air conditioners provided just at the click of a button.



## 01 Compressor Frequency image

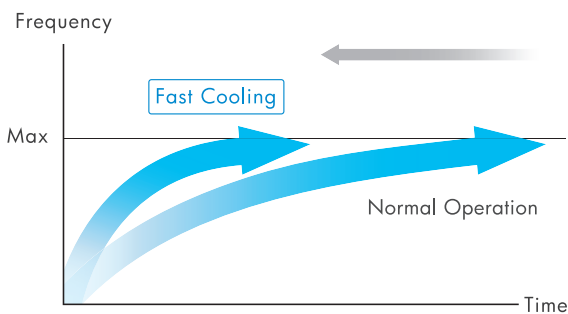

Pressing the Fast Cooling button makes the compressor reach its maximum frequency remarkably faster than in Normal Operation.

## 02 Air Outlet Temperature

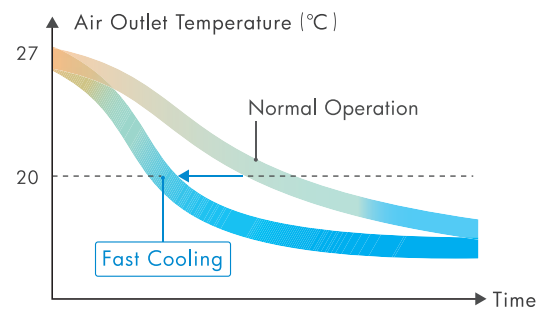

Lowers the air outlet temperature faster than Inverter Normal Operation.

## 03 Thermography

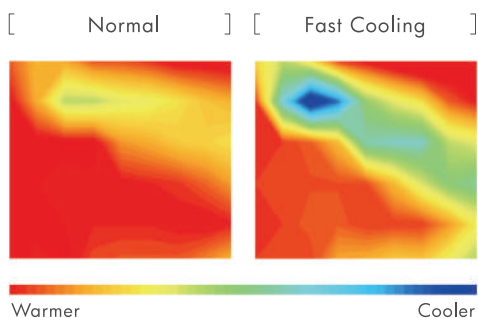

Quickly cools the room with the highest-volume, and low-temperature airblow at 2 min. after operation.

## 04 Fast Cooling button

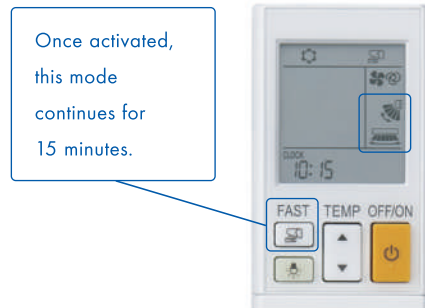

Fast Cooling mode starts immediately with the push of a button. According to preference, air direction can be changed freely.



## Long airflow

Delivers substantial and comfortable airflow

Projects air current up to 12 meters. Suitable even for living rooms.



### Model comparison

○ MSY-GR10/13/15VF	8 m
○ MSY-GR18/22/26VF	12 m

\* It's available when air direction horizontal and fan speed S-Hi.



## Auto Vane Control Up and Down/Left and Right

Auto vanes can be moved left and right, and up and down using the remote controller.

### Horizontal Airflow / Auto Vane Control

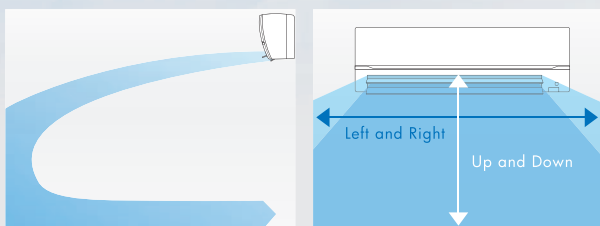

Auto Vane Control Button

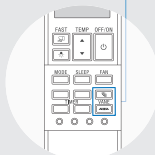

### Left & Right

\* Not available for MSY-GR10/13/15VF

Auto vanes can be set at 6 position and swing.



### Up & Down

Auto vanes can be set at 5 positions and swing.





# Dual Barrier Coating

Dual Barrier Coating prevents dust and greasy dirt from getting into the air conditioner

## State-of-the-art coating technology

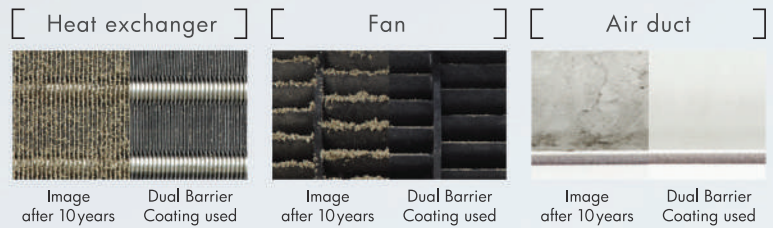
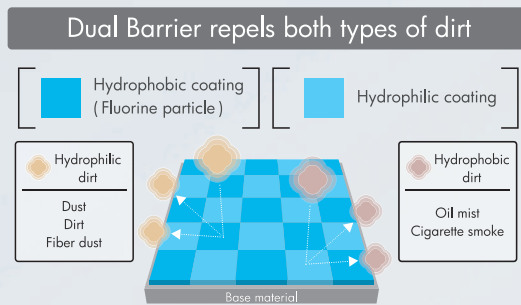

Dirt is generally classified into two groups. Dual Barrier Coating works as a two barrier coating with blended "fluorine particles" that prevent hydrophilic dirt penetration and "hydrophilic particles" that prevent hydrophobic dirt.

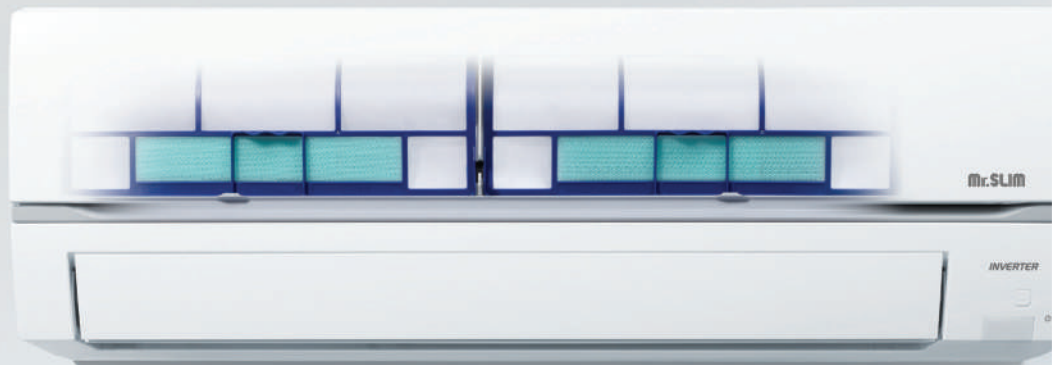

# Micro Particle Catching Filter (Optional) and High Density Filter (Optional)

Effectively eliminate PM 2.5 and catch smaller dusts.

Effectively catches floating PM2.5 particles to maintain clean air in the room.

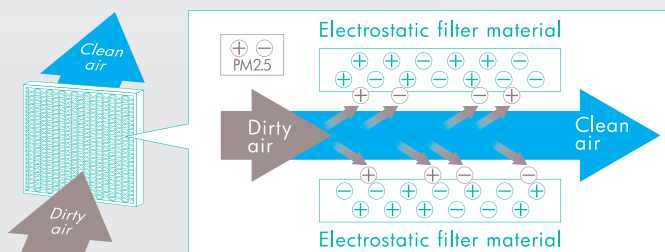

## [Comparison of Density of filters]

High Density Filter can prevent smaller dust from entering the inside of air conditioners.

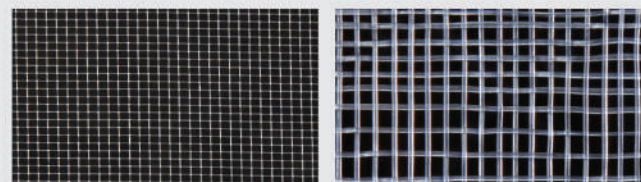

High Density Filter

Standard Filter



# Quiet Operation

The indoor unit level is as low as 18 dB (A) offering a peaceful indoor environment.

(Model GR10)

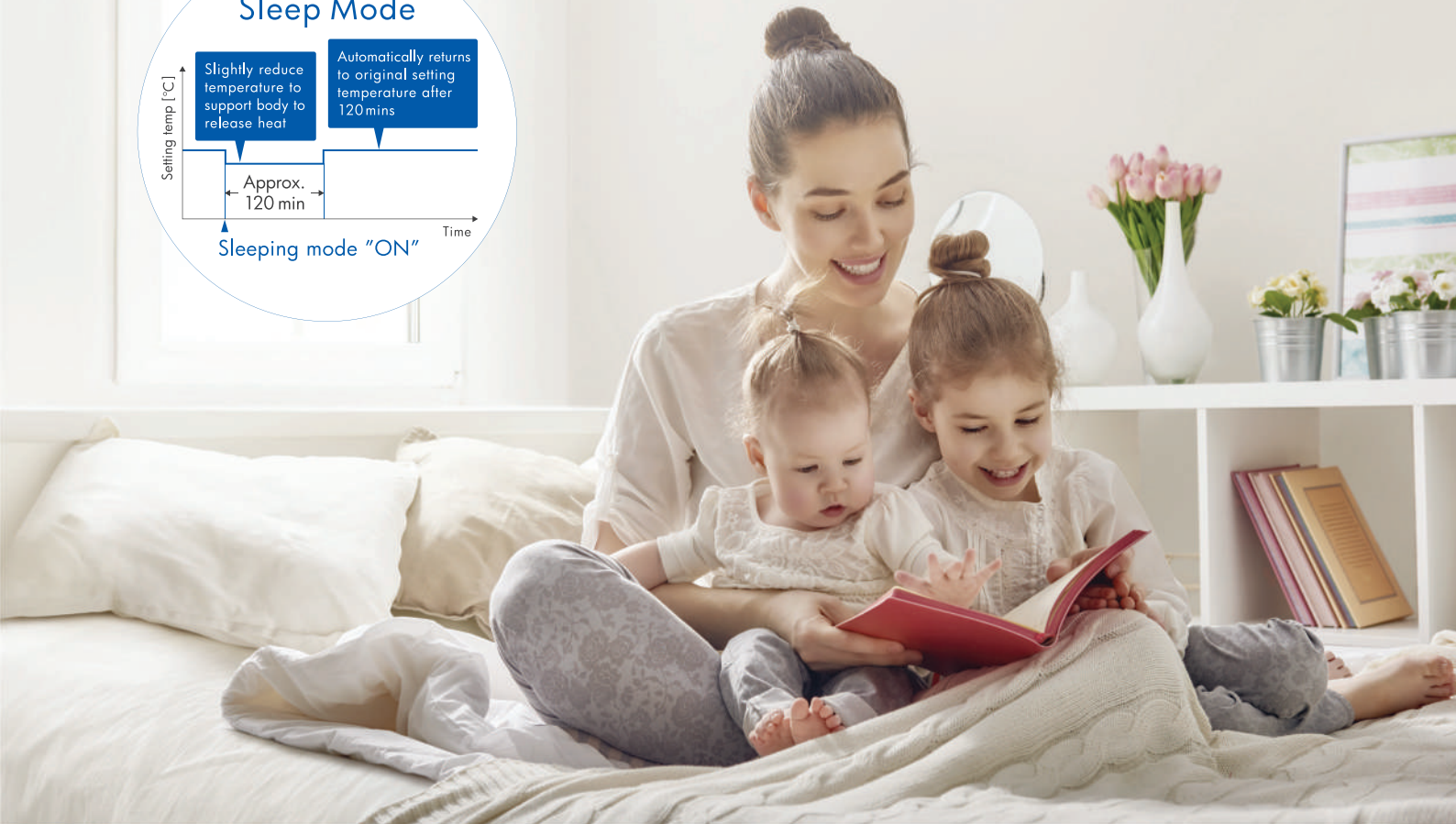
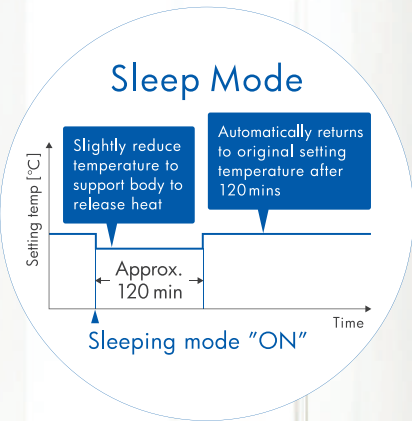

# Aerodynamics Technology

Realizing the quietest room air conditioner, MITSUBISHI ELECTRIC have ever launched.

(Model GR10)

## Cross-Flow-Fan



Our unique Cross Flow Fan construction guides air smoothly along each rotating blade as it simultaneously takes in and expels air. This allows for highly efficient delivery of powerful and refreshing airflow.

## Optimized aero design

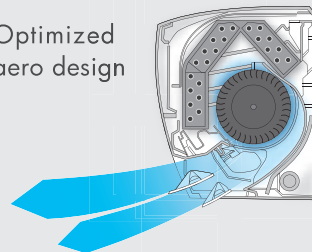

Optimized aero design utilizing 2 horizontal vanes and fixing suitable position of lower vane.



# New Remote Controller

New stylish and compact remote controller features easy-read big display and simple button position with fundamental functions.



## LED Backlight with luminous button

Once the luminous backlight button is pressed, the setting can be easily checked in the dark.

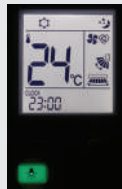

## Simple and intuitive buttons



## Error code display

Error codes are displayed on the remote controller for trouble shooting.



\* For the details, please refer to the operating Instructions

## A Remote Controller That Fits You

Its compact design creates the perfect fit for your hand.



# GR Series

## Indoor Unit

GR10/13/15



| H280 x W838 x D229 (mm) |

GR18/22/26

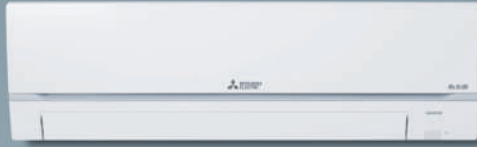

| H325 x W1100 x D257 (mm) |

## Remote Controller



## Outdoor Unit

GR10/13



| H538 x W699 x D249 (mm) |

GR15/18



| H550 x W800 x D285 (mm) |

GR 22



| H714 x W800 x D285 (mm) |

GR 26









| H880 x W840 x D330 (mm) |

## Functions and Features

	Joint Lap DC Motor		Magnetic Flux Vector Sine Wave Drive		Reluctant DC Rotary Compressor		Heat Caulking Fixing Method
	Vector Wave Eco Inverter		PAM (Basic)		Anti-Mold filter		High Density filter (Optional part)
	Micro Particle Catching Filter (Optional part)		Electrostatic Anti-allergy Enzyme Filter (Optional part)		Dual Barrier Coating		Horizontal vane swing
	Vertical vane swing		Auto vane control (Left & Right, Up & Down)		Double Horizontal vane		Auto Fan Speed Mode
	Long Airflow *GR18/22/26		LED Back Light with Luminous button		Fast Cooling Mode		Sleep Mode
	24-Hour On/Off programmable timer		Auto Restart		Error Code display on Remote Controller		Blue Fin for Outdoorcondenser (Corrosion toughness)

# Specifications - GR Series

Type	Cooling only								
Model name	Indoor unit		MSY-GR10VF-DA1	MSY-GR13VF-DA1	MSY-GR15VF-DA1	MSY-GR18VF-DA1	MSY-GR22VF-DA1	MSY-GR26VF-DA1	
	Outdoor unit		MUY-GR10VF-DA1	MUY-GR13VF-DA1	MUY-GR15VF-DA1	MUY-GR18VF-DA1	MUY-GR22VF-DA1	MUY-GR26VF-DA1	
Refrigerant	R32								
Power supply	Source	Single phase 230V, 50Hz							
		Outdoor power supply							
Capacity	Rated (Min-Max)	kW	2.8 (1.1-3.4)	3.7 (1.4-4.1)	4.2 (1.6-4.8)	5.2 (1.8-6.0)	6.6 (1.8-7.2)	7.6 (2.1-9.2)	
	TR	TR	0.75	1.00	1.25	1.50	1.90	2.20	
Total Input	Rated (Min-Max)	kW	0.76 (0.23-1.07)	1.01 (0.32-1.31)	1.18 (0.35-1.67)	1.36 (0.34-1.84)	1.72 (0.33-2.15)	2.09 (0.45-3.33)	
ISEER			5.00	5.02	5.01	5.00	5.00	4.80	
SPL	Indoor unit (Silent-Lo-Med-Hi-SHi)	dB(A)	18-24-31-38-42	19-24-31-38-43	25-29-35-40-46	27-33-38-44-49	28-36-41-45-51	30-37-42-46-53	
Air Volume	Indoor unit (Silent-Lo-Med-Hi-SHi)	CFM	141-187-254-335-403	152-187-254-335-445	194-230-293-364-466	318-396-466-554-710	339-424-512-597-777	346-452-540-625-809	
Operating Current		A	3.8	4.8	5.4	6.2	7.6	9.2	
Indoor unit	Dimensions (H x W x D)	mm	280*838*229	280*838*229	280*838*229	325*1100*257	325*1100*257	325*1100*257	
	Weight	kg	10	10	10	17	17	17	
Outdoor unit	Dimensions (H x W x D)	mm	538*699*249	538*699*249	550*800*285	550*800*285	714*800*285	880*840*330	
	Weight	kg	21.5	24.5	30	31.5	38	48	
Ext.Piping	Diameter Liquid	mm (inches)	6.35(1/4)	6.35(1/4)	6.35(1/4)	6.35(1/4)	6.35(1/4)	6.35(1/4)	
	Diameter Gas	mm (inches)	9.52(3/8)	9.52(3/8)	9.52(3/8)	12.7(1/2)	15.88(5/8)	15.88(5/8)	
	Max.Length Out-In	m	20	20	20	20	30	30	
	Max.Height Out-In	m	12	12	12	12	15	15	
Star Rating									

Pre filter	ANTI-MOLD							
Air cleaning filter	Electrostatic Anti Allergy Enzyme Filter(OPT), Microparticle catching filter(PM2.5)(OPT)							
Timer			24h	24h	24h	24h	24h	24h
Vertical Swing			o	o	o	o	o	o
Control wiring (Copper)	ODU to IDU	Core No. x Sq.mm	4C x 1.0	4C x 1.0	4C x 1.0	4C x 1.0	4C x 1.0	4C x 1.0
Power cable (Copper)	To ODU	Core No. x Sq.mm	3C x 1.0	3C x 1.0	3C x 1.0	3C x 1.0	3C x 2.0	3C x 2.5
ODU Breaker Size	To ODU	A	10	10	10	10	16	20



# GN Series

(Inverter Cooling Only)



## Dual Barrier Coating



**DC**  
**Inverter**

---

COMFORT WITH  
PROTECTION

---



MSY-GN 18/22 VF



## Dual Barrier Coating



Reduce the attachment of "dust" and "oil" mist

Coating on the parts inside our Air Conditioners

• Heat Exchanger • Line flow fan • Air duct



Help the unit working at full performance



Reduce dirt which is the cause of bad smell



With less dirt, the necessity of cleaning the air-conditioner is also less

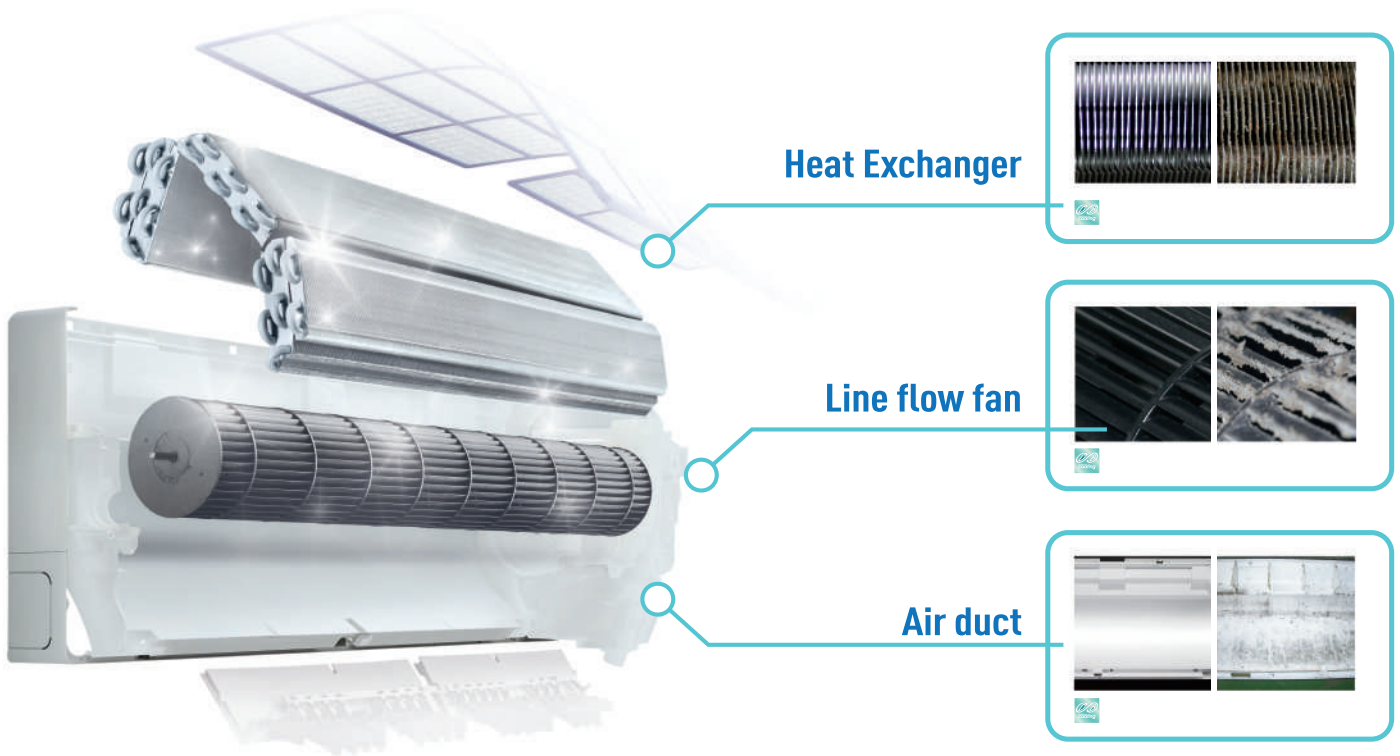

## Reduce dust attachment: Full performance of cooling capacity

New technology from Mitsubishi Electric Mr. Slim which is invented to protect the air conditioner in order to be able to operate efficiently. With the special qualification of coating material which help to reduce the attachment of dust and oil mist which are mixed in the air that reduce the cause of odour and air conditioner cleaning burden.



## New refrigerant which is environmental Friendly

Technology for air con and for green world for everyone. New refrigerant which do not destroy ozone and reduce green affect.

### If the inside of your air conditioner gets dirty.





## Inverter Technology

Mitsubishi Electric inverters ensure superior performance, including the optimum control of operational frequency. As a result, optimum power is applied in all cooling / heating ranges and maximum comfort is achieved while consuming minimal energy. Fast, comfortable operation at an amazingly low running cost - that's the Mitsubishi Electric promise.

## Inverters - How They Work

Inverters electronically control the electricity voltage, current and frequency of electronic devices, such as the compressor motor in the air conditioner. They receive information from sense-monitoring operation conditions and adjust the revolution speed of the compressor, which directly regulates the air conditioner output. Optimum control of operation frequency results in eliminating the consumption of excessive electricity and providing the most comfortable room environment.

## Advanced Inverter Control - Efficient Operation All The Time

Mitsubishi Electric's cutting-edge inverter technology is crafted to provide automatic adjustment of operation load according to need. This reduces excessive consumption of electricity and thereby achieves an Energy Rank 'A' rating for 25 - 35 classes and 'A+' for 50 classes in accordance with the latest European energy label standards.

### TRUE COMFORT COMPARISON OF AIR CONDITIONER OPERATION CONTROL WITH AND WITHOUT INVERTER.

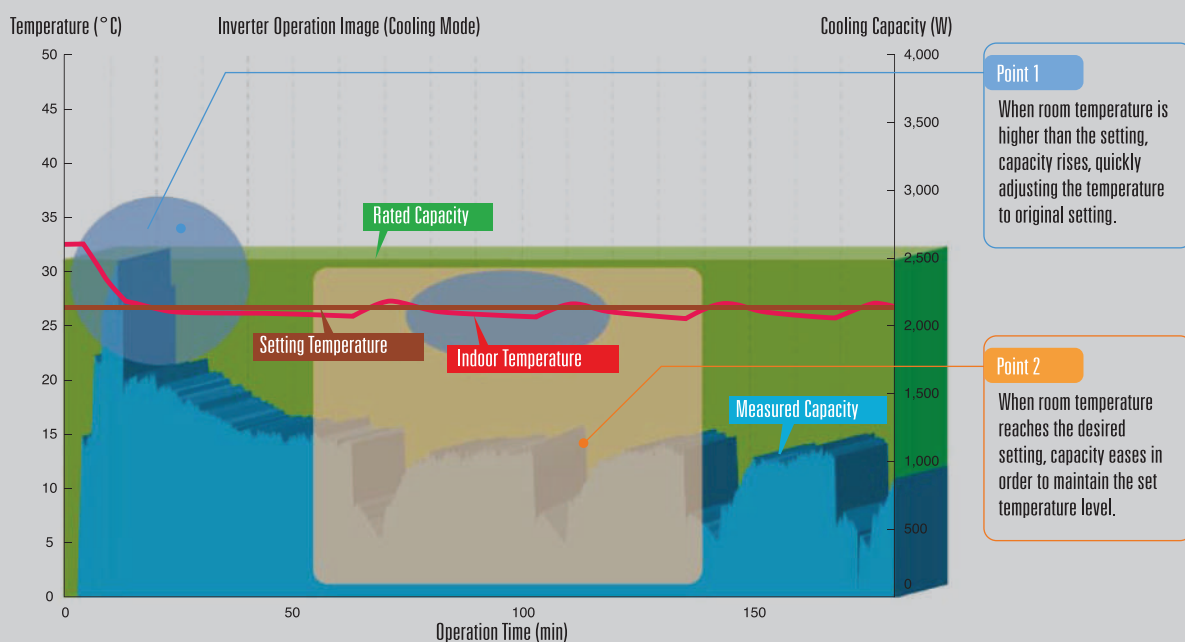

## Quick And Powerful

Increasing the compressor motor speed by controlling the operational frequency ensures a powerful output on start-up. It brings the room temperature to a comfortable level faster than units unequipped with an inverter. Hot rooms are cooled, and cold rooms are heated faster and more efficiently.

## Room Temperature Maintained

The compressor motor operating frequency and the change in room temperature is monitored to calculate the most efficient waveform to maintain a comfortable room temperature. This eliminates the large temperature swings, common with non-inverter systems and guarantees a pleasant, comfortable environment.

# OUR TECHNOLOGY



**Blue fin**  
(anti corrosion)

Highly effective Anti-corrosion HEX is used in all outdoor units.

## IDU Anti-corrosion Coating



Before Coating



After Coating

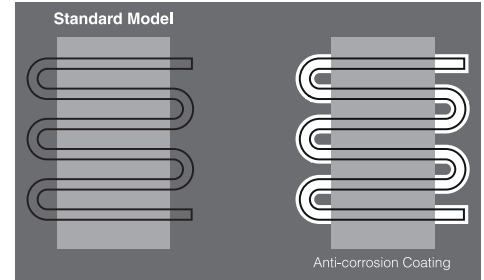

'Anti-corrosion Coating' is done to prevent gas leakage from AC coil bend which is very frequent in Indian market conditions

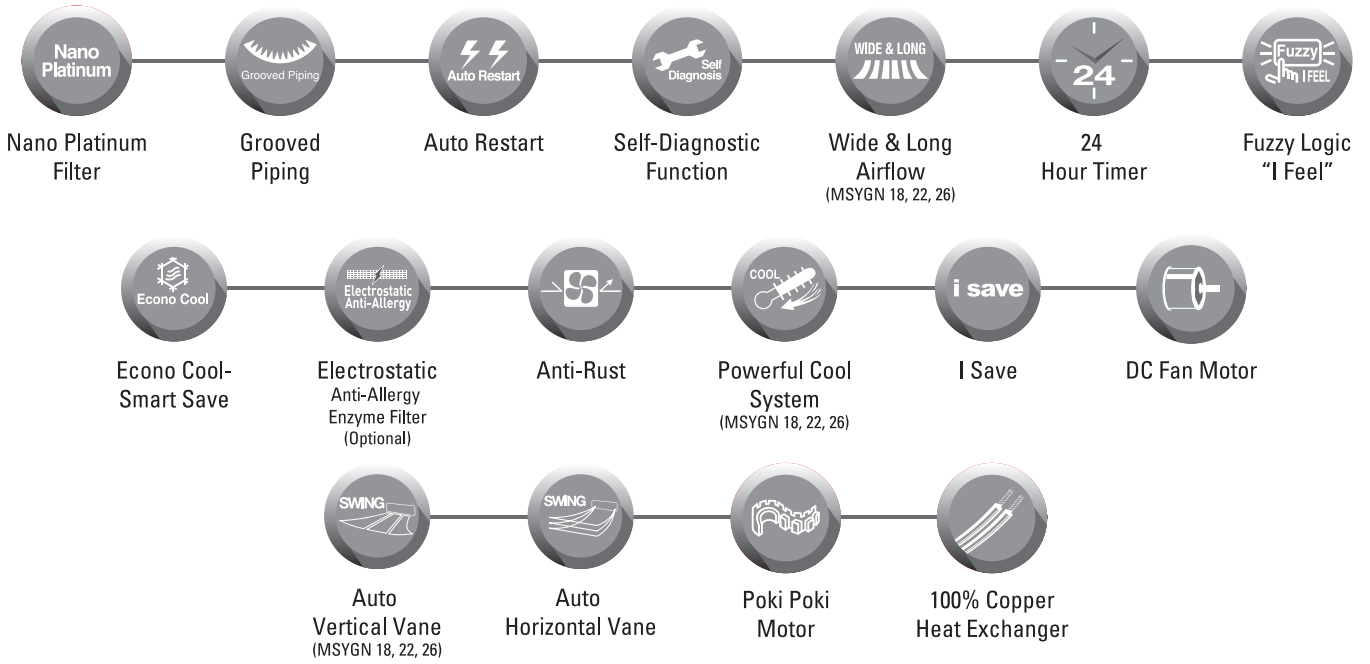

## MSY / MUY - GN Series



MSY-GN 10/13/15



MSY-GN 18/22



MSY-GN 26



MUY-GN 10/13/15/18





MUY-GN 22



MUY-GN 26

# SPECIFICATIONS

## MSY-GN Series

Type	Cooling only				
Model name	Indoor unit		MSY-GN10VF	MSY-GN13VF	MSY-GN15VF
	Outdoor unit		MUY-GN10VF	MUY-GN13VF	MUY-GN15VF
Refrigerant	R32				
Power supply	Source	Single phase, 230V, 50Hz			
		Outdoor power supply			
Capacity	Rated*	kW	2.8	3.7	4.2
	(Min-Max)	kW	(1.1-3.4)	(1.1-4.1)	(0.9-4.8)
	TR	TR	0.75	1.00	1.25
Total Input	Rated*	kW	0.76	1.00	1.16
ISEER			4.85	4.81	4.74
SPL	Indoor unit (Silent-Lo-Med-Hi-SHi)	dB(A)	19-24-31-38-44	19-24-31-38-44	26-29-35-40-46
Air Volume	Indoor unit (Silent-Lo-Med-Hi-SHi)	CFM	145-184-255-327-406	145-184-255-327-459	160-214-285-363-459
Operating Current		A	3.8	4.8	5.4
Indoor Unit	Dimensions (H x W x D)	mm	290 x 799 x 232	290 x 799 x 232	290 x 799 x 232
	Weight	kg	9	9.5	9.5
	Breaker Size (MCB required)	A	-	-	-
Outdoor Unit	Dimensions (H x W x D)	mm	550*800*285	550*800*285	550*800*285
	Weight	kg	28.5	32	32
	Breaker Size (MCB required)	A	10	10	10
Ext. Piping	Diameter Liquid	mm (inches)	6.35 (1/4)	6.35 (1/4)	6.35 (1/4)
	Diameter Gas	mm (inches)	9.52 (3/8)	9.52 (3/8)	9.52 (3/8)
	Max. Length Out-In	m	20	20	20
	Max. Height Out-In	m	12	12	12
Star Rating					

Pre filter	NANO PLATINUM				
Air cleaning filter	ELECTROSTATIC ANTI-ALLERGY ENZYME FILTER (Option)				
Timer	24hr				
Vertical Swing	-				
Wide and Long	-				
Control wiring (Copper)	ODU to IDU (Copper)	Sq.mm	4C x 1	4C x 1	4C x 1
Power cable (Copper)	To ODU	Sq.mm	3C x 1.0	3C x 1.0	3C x 1.0
ODU Breaker Size	To ODU	AMP	10	10	10

**\*Note:** Condition | Indoor 27°C DB/ 19°C WB | Outdoor 35°C DB | Indoor- outdoor piping length: 5m

Type	Cooling only				
Model name	Indoor unit		MSY-GN18VF	MSY-GN22VF	MSY-GN26VF
	Outdoor unit		MUY-GN18VF	MUY-GN22VF	MUY-GN26VF
Refrigerant	R32				
Power supply	Source	Single phase, 230V, 50Hz			
		Outdoor power supply			
Capacity	Rated*	kW	5.2	6.6	7.6
	(Min-Max)	kW	(1.5-6.0)	(1.5-7.2)	(2.4-9.2)
	TR	TR	1.50	1.90	2.20
Total Input	Rated*	kW	1.43	1.83	2.00
ISEER			4.58	4.65	4.79
SPL	Indoor unit (Silent-Lo-Med-Hi-SHi)	dB(A)	28-33-38-44-49	29-37-41-45-49	30-37-41-45-51
Air Volume	Indoor unit (Silent-Lo-Med-Hi-SHi)	CFM	303-379-430-529-650	240-322-430-522-603	308-378-449-520-734
Operating Current		A	6.6	8.2	8.8
Indoor Unit	Dimensions (H x W x D)	mm	305 x 923 x 250	305 x 923 x 250	325 x 1100 x 238
	Weight	kg	12.5	12.5	15
	Breaker Size (MCB required)	A	-	-	-
Outdoor Unit	Dimensions (H x W x D)	mm	550*800*285	714*800*285	880*840*330
	Weight	kg	32	37	48.5
	Breaker Size (MCB required)	A	10	16	20
Ext. Piping	Diameter Liquid	mm (inches)	6.35 (1/4)	6.35 (1/4)	6.35 (1/4)
	Diameter Gas	mm (inches)	12.7 (1/2)	12.7 (1/2)	12.7 (1/2)
	Max. Length Out-In	m	20	30	30
	Max. Height Out-In	m	12	12	15
Star Rating					

Pre filter		NANO PLATINUM			
Air cleaning filter		ELECTROSTATIC ANTI-ALLERGY ENZYME FILTER (Option)			
Timer		24hr, Weekly			
Vertical Swing		•			
Wide and Long		•			
Control wiring (Copper)	ODU to IDU (Copper)	Sq.mm	4C x 1	4C x 1	4C x 1
Power cable (Copper)	To ODU	Sq.mm	3C x 1.0	3C x 2.0	3C x 2.5
ODU Breaker Size	To ODU	AMP	16	16	20

**JS**  
Series



**STRONG ON COOLING  
BIG ON SAVINGS**



# MITSUBISHI ELECTRIC

## Advanced ME Inverter Technology

Mitsubishi Electric leverages its **cutting-edge production technologies** to manufacture world-class products in its **state-of-the-art assembly lines** ensuring complete peace of mind for its customers across the globe.

Capitalizing on our **century-old experience and expertise** in understanding customer needs, we manufacture our own key components like **Inverter Power Module, Compressors, Propeller Fan, DC Motors, etc.** Our **advanced inverter technologies** have enabled us to achieve powerful and desired cooling comfort without compromising on **energy efficiency**.

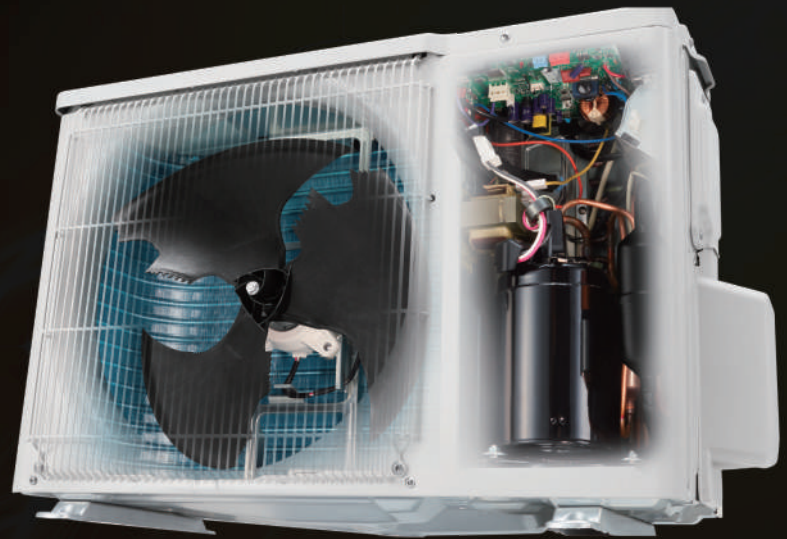

## MITSUBISHI ELECTRIC Inverter Power Module

The Inverter Power Module is the brain of the air conditioner. It minimizes power consumption by adjusting the frequency.

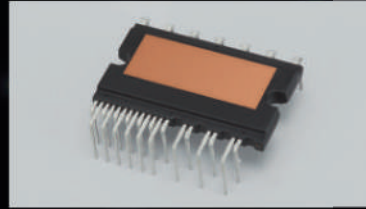

## MITSUBISHI ELECTRIC Propeller Fan and DC Fan Motor

### Propeller Fan



Newly designed propeller fan maximizes airflow efficiency. It delivers the most air volume with the least noise.

### DC Fan Motor



A highly efficient DC Fan motor drives the fan of the outdoor unit. Efficiency is much higher than an equivalent AC motor.

## MITSUBISHI ELECTRIC Compressor

The compressor is the heart of the air conditioner. Employing Mitsubishi Electric's proprietary technology, we are able to achieve both high efficiency and high power.

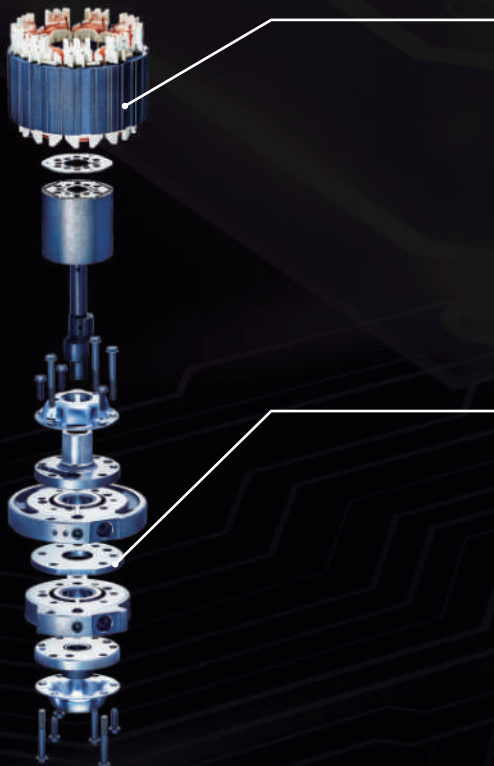

### Poki-Poki Motor



Dramatically enhanced motor efficiency utilising original dense winding technology.

### Heat Caulking



Original heat caulking method minimizes cylinder distortion for even greater efficiency.



## Fast Cooling

Mitsubishi Electric, a global leader in air conditioning, understands its customer requirement better than anyone else.

At Mitsubishi Electric, we invest great care in designing our product features, Instant relief from scorching heat is one such desire met successfully through the Fast Cooling feature in our air conditioners provided just at the click of a button.

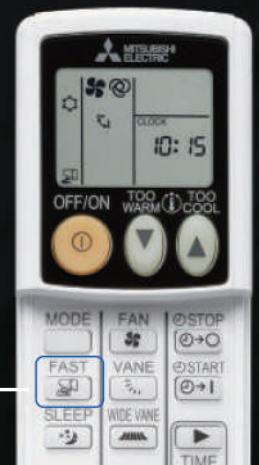

## 01 Fast Cooling button

Once activated, this mode continues for 15 minutes.

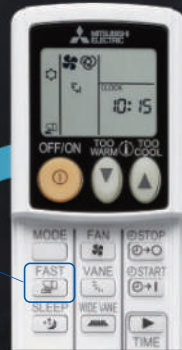

Fast Cooling mode starts immediately with the push of a button. According to preference, air direction can be changed freely.

## 02 Thermography

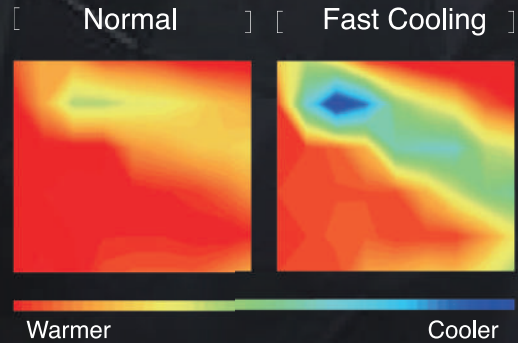

Quickly cools the room with the highest-volume and low-temperature airblow at 2 min. after operation

## 03 Compressor Frequency Image

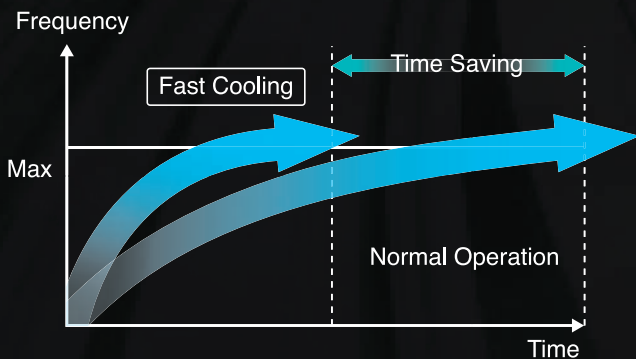

Pressing the Fast Cooling button makes the compressor reach its maximum frequency remarkably faster than in Normal Operation.

## 04 Air Outlet Temperature

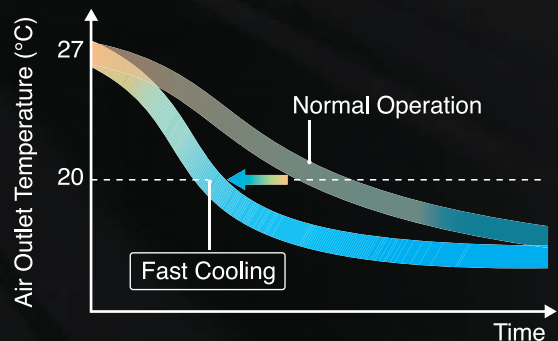

Lowers the air outlet temperature faster than Inverter Normal Operation.

# Micro Particle Catching Filter (PM 2.5) and High Density Filter

Effectively eliminates floating PM2.5 and smaller dust particles.



## 01 Micro Particle Catching Filter<sup>1</sup>

Effectively catches floating PM 2.5 particles to maintain clean air in the room.

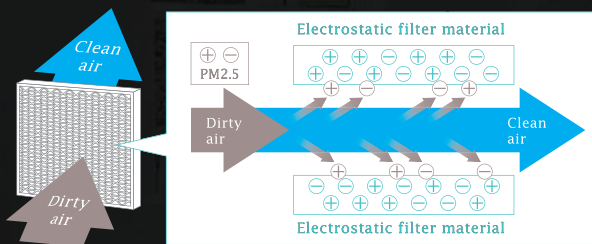

Model name:  
MAC- EMF 515 FT-E

Electrostatic material removes PM 2.5 from the air and absorbs it when passing through the filter.

## 02 High Density Filter<sup>1</sup>

High Density Filter can prevent smaller dust particles from entering inside air conditioners

Comparison of density of filters



Standard Filter

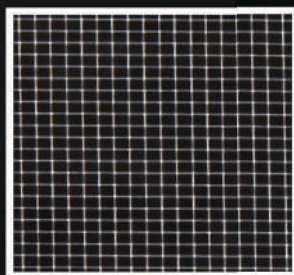

High Density Filter  
(Optional parts)

Model name:  
MAC- HDJ 519 FT-E | MAC- HDH 519 FT-E

<sup>1</sup>(Optional parts)

# Long Airflow

Delivers substantial and comfortable airflow



Delivers Long and comfortable airflow upto 12m<sup>1</sup> suitable for living rooms

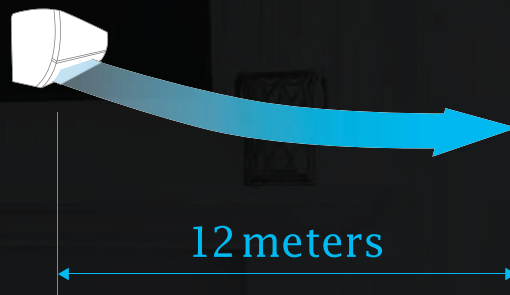

MITSUBISHI ELECTRIC launched the World's First\* Room Air Conditioner equipped with Cross-Flow Fan in 1968.

\*Based on Euromonitor International Research

## Cross-Flow Fan Technology



Our unique Cross-Flow Fan construction guides air smoothly along each rotating wing as it simultaneously intakes and expels air. This allows for highly efficient delivery of powerful and refreshing airflow.

<sup>1</sup>Available in MSY-JS18/22

# Dual Barrier Coating

Dual Barrier Coating prevents dust and greasy dirt from getting into the air conditioner

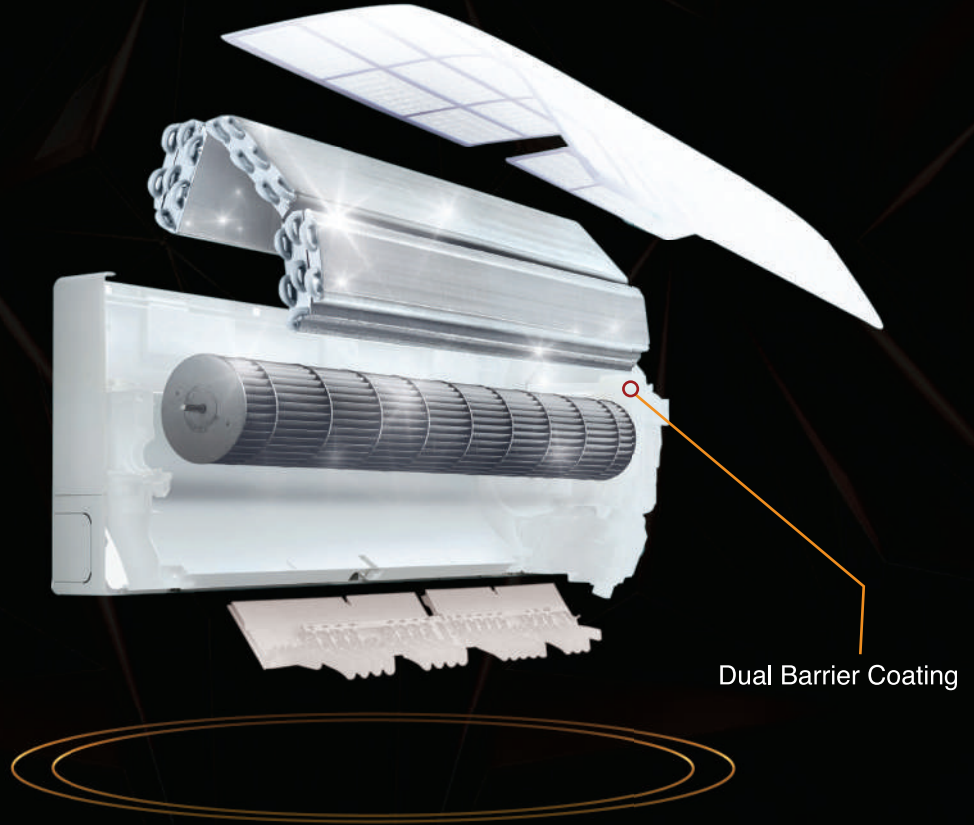

## State-of-the-art coating technology

### Dual Barrier Coating both types of dirt

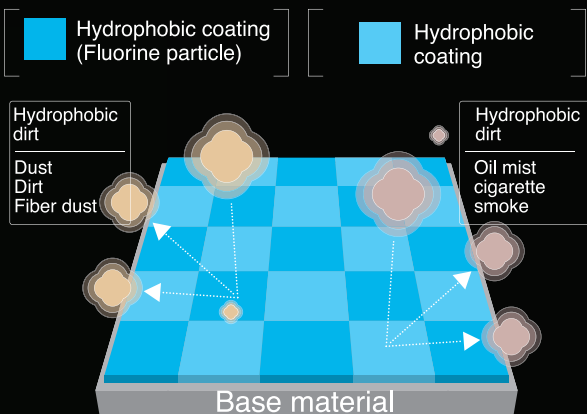

### Comparison of Dirt on Fan

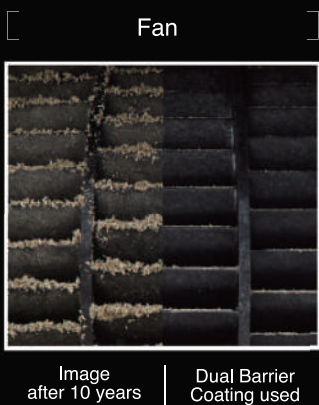

Dirt is generally classified into two groups. Dual Barrier Coating works as two-barrier coating with blended "fluorine particles" that prevent hydrophilic dirt penetration and "hydrophilic particles" that prevent hydrophobic dirt.

# Auto Vane Control<sup>1</sup>

Up and Down / Left and Right

Auto vanes can be moved left and right, and up and down using the remote controller.

<sup>1</sup>Only for JS18/22VF

## Horizontal Airflow/Auto Vane Control

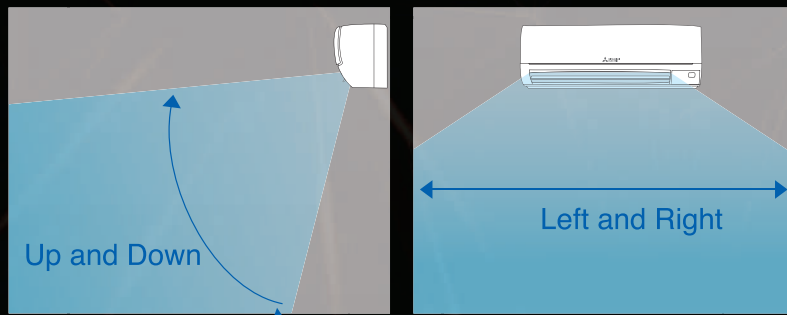

Auto Vane Control Button

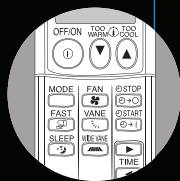

### Left and Right

Auto vanes can be set at 5 position and swing.

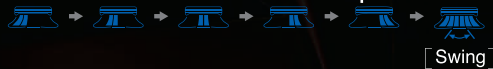

### Up and Down

Auto vanes can be set at 5 position and swing.



## Useful functions

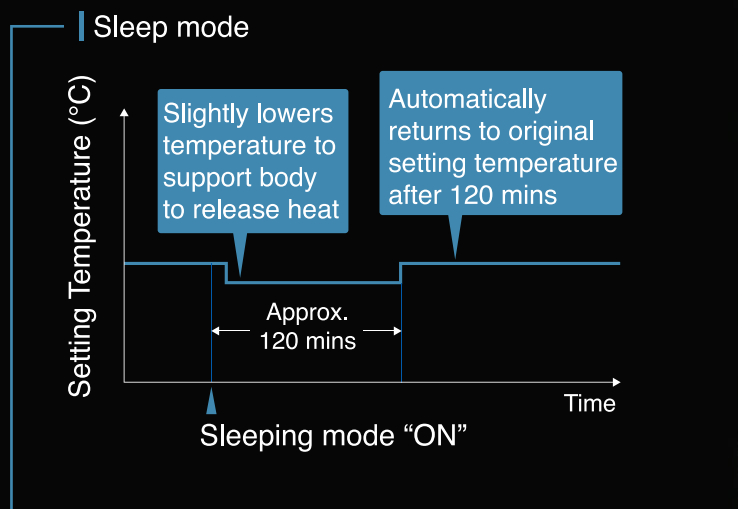

## Error code display

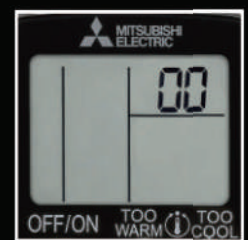



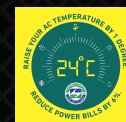

Error codes are displayed on the remote controller for troubleshooting

\* For details, please refer to the operating instructions

# Functions & Features



 Joint Lap DC Motor	 Horizontal vane swing
 Magnetic Flux Vector Sine Wave Drive	 Auto Vane Control Left & Right (*Only for MSY-JS18/22VF)
 Reluctant DC Rotary Compressor	
 Heat Caulking Fixing Method	 Auto Fan Speed Mode
 Vector Wave Eco Inverter	 Long Airflow (*Only for MSY-JS18/22VF)
 PAM (Basic)	 Fast Cooling Mode
 Grooved Piping	 24-Hour On/Off Programmable timer (*Only for MSY-JS18/22VF)
 Anti-Mold Filter	 12-Hour On/Off Timer (*Only for MSY JS13/15VF)
 High Density Filter (Optional part)	 Auto Restart
 Micro Particle Catching Filter (Optional part)	 Sleep Mode
 Electrostatic Anti-allergy Enzyme Filter (Optional part)	 Error Code display on Remote Controller
 DUAL BARRIER COATING (Fan)	 Luminous Button
 Single Coating	 Blue Fin for Outdoor Condenser (Corrosion toughness)

# Product Specifications



- Rating Conditions Cooling -  
Indoor: 27°C (80°F) DB,  
19°F (66°F) WB,  
Outdoor: 35°C (95°F)
- Refrigerant piping length (one-way): 5m (16.4ft)
- Total input based on the indicated voltage (Indoor/Outdoor):  
1 phase 230V 50Hz.

Type			Cooling only			
	Indoor Unit		MSY-JS13VF	MSY-JS15VF	MSY-JS18VF	MSY-JS22VF
	Outdoor Unit		MUY-JS13VF	MUY-JS15VF	MUY-JS18VF	MUY-JS22VF
			R32			
Power Supply	Source		Single phase 230V, 50hz			
			Outdoor power supply			
Capacity	Rated (Min-Max)	kW	3.6 (0.9-3.7)	4.2(1.2-4.2)	5.2 (1.5-5.7)	6.6 (1.6-6.7)
	TR	TR	1.00	1.25	1.50	1.9
Total Input	Rated (Min-Max)	kW	1.27(0.30-1.35)	1.44(0.35-1.59)	1.68(0.35-2.04)	2.01(0.34-2.20)
ISEER			4.15	4.23	4.23	4.22
SPL	Indoor Unit Quiet-Lo-Med-Hi-SHi	db(A)	22-28-36-40-43	26-31-37-42-46	26-33-40-44-49	27-37-41-45-51
Air Volume	Indoor Unit Quiet-Lo-Med-Hi-SHi	CFM	190-247-331-397-452	197-274-352-419-471	230-297-392-459-569	300-399-487-576-660
Operating Current	Rated	A	6	6.7	7.5	9.1
Indoor Unit	Dimensions (H x W x D)	mm	280 x 838 x 228	280 x 838 x 228	305 x 923 x 262	305 x 923 x 262
	Weight	kg	8.5	8.5	11.5	12.5
Outdoor Unit	Dimensions (H x W x D)	mm (inches)	538 x 699 x 249	538 x 699 x 249	550 x 800 x 285	714 x 800 x 285
	Weight	kg	21	24.5	31.5	37.0
Ext. Piping	Diameter Liquid	mm (inches)	6.35(1/4)	6.35(1/4)	6.35(1/4)	6.35(1/4)
	Diameter Gas	mm (inches)	9.52(3/8)	9.52(3/8)	12.7(1/2)	12.7(1/2)
	Max. Length Out-In	m	20	20	20	30
	Max. Height Out-In	m	12	12	12	15
Star Rating (2018-2021)			4 star	4 star	4 star	4 star

Pre Filter			ANTI-MOLD/HIGH DENSITY FILTER (Optional)			
Air Cleaning Filter			ELECTROSTATIC ANTI-ALLERGY ENZYME FILTER (Optional), MICROPARTICLE CATCHING FILTER (Optional)			
Timer			12h	12h	24h	24h
Vertical Swing	Auto		-	-	O	O
	Manual		O	O	-	-
Control Wiring (Copper)	ODU to IDU	Core No. x Sq.mm	4C x 1.0	4C x 1.0	4C x 1.0	4C x 1.0
Power Cable (Copper)	To ODU	Core No. x Sq.mm	3Cx1.0	3C x 1.0	3C x 1.0	3C x 1.0
ODU Breaker Size	To ODU	A	10	10	10	16

# MSY- JS Series

## Indoor Unit

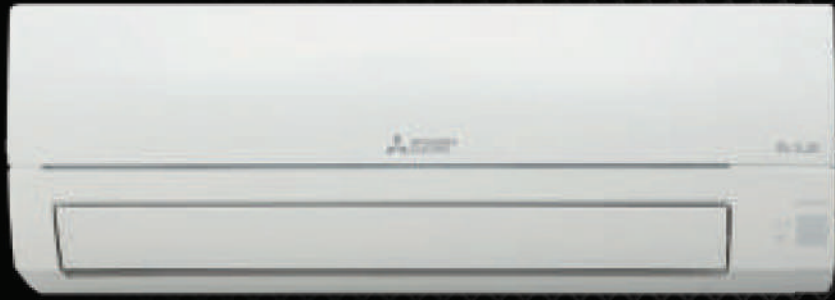

**MSY-JS 13/15VF**  
H280 x W838 x D228 (mm)

## Remote Controller



Luminous buttons

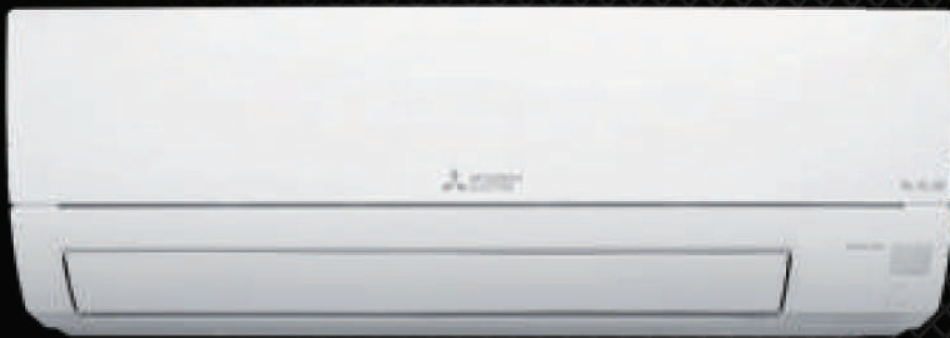

**MSY-JS 18/22VF**  
H305 x W923 x D262 (mm)



Luminous buttons



## Outdoor Unit



| MUY-JS 13/15VF

H538 x W699 x D249 (mm)



| MUY-JS 18VF

H550 x W800 x D285 (mm)



| MUY-JS 22VF

H714 x W800 x D285 (mm)

Changes for the Better

Download from, [mepbali.net](http://mepbali.net)

 **MITSUBISHI  
ELECTRIC**  
AIR CONDITIONERS

  
KIRIGAMINE

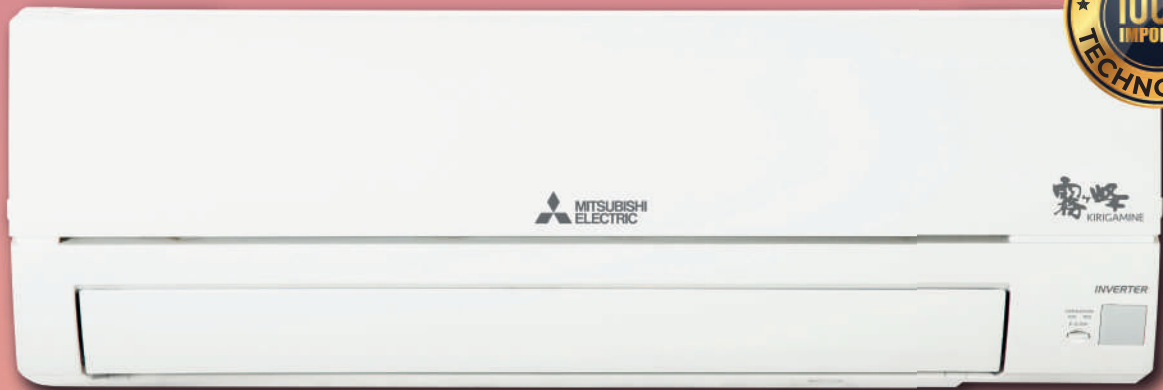

# JAPAN'S FAVOURITE NOW IN INDIA!

◆ CLEAN AIR ◆ FAST COOLING ◆ LONG AIR-FLOW

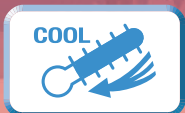

Fast Cooling  
Mode



PM 2.5  
Filter



Dual Barrier  
Coating



Long  
Air Flow



# ORIGIN OF “KIRIGAMINE”

The Longest-running Air Conditioner Brand



霧峰  
KIRIGAMINE

The late 1960s was the phase of “the Japan’s plan to double national income,” which allowed people to significantly raise the standard of living. Under those circumstances, more and more people desired to have a cottage in a summer resort, feeling refreshed in a highland. In order to enhance the association of Air Conditioners with such feeling summer resorts evoke, **Mitsubishi Electric** branded window-mounted types as “**Karuizawa**”, the floor-mounted type as “**Kamikochi**”, and the wall-mounted type as “**Kirigamine**,” all of which were named after famous summer resorts in Suwa City of Japan.

**Kirigamine Highlands** is an eminent scenic spot with a splendid view of Suwa City in Nagano, **Mt. Fuji**, the Yatsugatake mountain range and alpine flora of each season. With a strong updraft around it, the upland is also known as the birthplace of gliding in Japan.

In spring 2017, “**Kirigamine**,” in honor of the brand’s 50<sup>th</sup> anniversary, was awarded a letter of gratitude from Suwa City for its contribution towards enhancing tourism & making Suwa City a popular tourist destination in Japan.

**Mitsubishi Electric** will continue to dedicate itself to deliver refreshing comfort to all customers, thus enabling them to feel as if they were in **Kirigamine Highlands**.

霧峰  
KIRIGAMINE



Window type  
**Karuizawa**



Floor standing  
**Kamikochi**



Wall mounted  
**Kirigamine**

# MITSUBISHI ELECTRIC

## Timeline of Progress

### 1954

Room Air Conditioners production started

### 1960

Introduced premium range of Air Conditioners: Window type as "**Karuizawa**" & Floor Mounted type as "**Kamikochi**"

### 1961

First in the industry to begin sales of **heat pump Air Conditioners** for residential use

### 1967

Exclusive premium range "**Kirigamine**" introduced for wall mounted type Air Conditioner

### 1968

First in the world to begin sales of separate wall Air Conditioners with **built-in "Line-Flow Fan"**

### 1971

Introduced **Japan's quietest, light all-plastic Air Conditioner**

### 1975

Introduced **slim Air Conditioner** with depth of 17cm.

### 1978

Introduced industry's first mounted "**Green Sign**" temperature indicator

### 1984

Introduced inverter-driven Air Conditioner with **wireless remote control** and **automatic ventilation flaps**

### 1986

Introduced body temperature control via "**automatic temperature control feature**"

### 1988

Introduced "**Twin-Fan Air Conditioner**" as the pioneer of comfortable air flow

### 1994

Introduced "**Panorama Eye**" (built-in sensor to detect location of people)

### 1995

Introduced "**Wide & Long Energy-saving**" Kirigamine with 120° wide air flow and industry top level energy saving

### 2000

Introduced "**I Feel Kirigamine**" equipped with the "**I Feel**" **multi-sensor system**, including the industry's first heat sensor to measure the temperature felt by room occupants

### 2005

Introduced the "**Kirigamine i-see Sensor (Move Eye)**" for wide-area living spaces

### 2007

Introduced the 8 Series equipped with the **human-sensing i-see sensor (Move Eye)** and **automatic cleaning** functions. Released the "**Zubdan Kirigamine**" specified for the use in cold areas

### 2010

**MITSUBISHI ELECTRIC INDIA** operations started

### 2012

Introduced the "**Hybrid Kirigamine**", which saves energy by automatically switching between '**cooling and heating**' and "**ventilation**"

### 2016

World's first '**Personal Twin Flow**' with different temperatures in the room

### 2017

Introduced **GN series with Dual Barrier Coating** feature first time in India

### 2019

Introduced **tropical inverter GRT series** in India

### 2021

New **Kirigamine** Models introduced in India



Mitsubishi Electric Corporation is an independent company like any other Mitsubishi group companies. It bears no legal affiliation to other companies that have the word "Mitsubishi" in their name or using the same logo except Mitsubishi Electric Group companies.

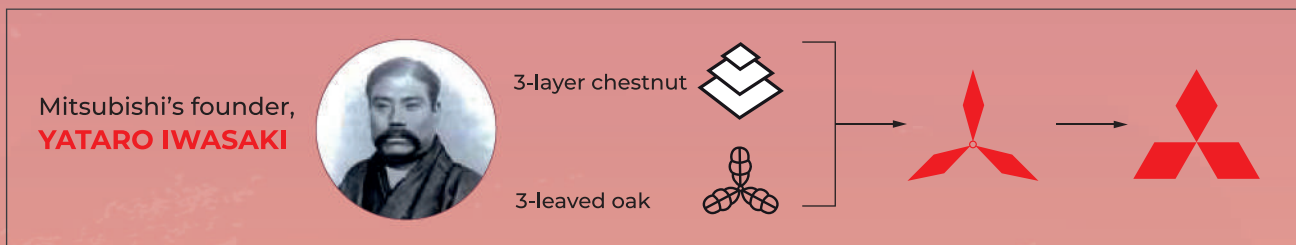

Our origins can be tracked back to Yataro Iwasaki (1835-1885), the founder of the Mitsubishi Group, from which Mitsubishi Electric was born. His philosophy of justice and duty to society is summarized in a creed articulated by Koyata Iwasaki, the fourth president of the Mitsubishi Electric and other Mitsubishi companies share these three tenets of Iwasaki's management philosophy.

- Corporate Responsibility to Society
- Integrity and Fairness
- Global Understanding through Business

Guided by this common heritage, Mitsubishi Electric transforms these words into action, pursuing thorough going compliance and a variety of philanthropic and environmental activities around the world.

# MITSUBISHI ELECTRIC

## Advanced ME Inverter Technology

Mitsubishi Electric leverages its **cutting-edge production technologies** to manufacture world-class products in its **state-of-the-art assembly lines** ensuring complete peace of mind for its customers across the globe.

Capitalizing on our **century-old experience and expertise** in understanding customer needs, we manufacture our own key components like **Inverter Power Module, Compressors, Propeller Fan, DC Motors, etc.** Our **advanced inverter technologies** have enabled us to achieve powerful and desired cooling comfort without compromising on **energy efficiency**.

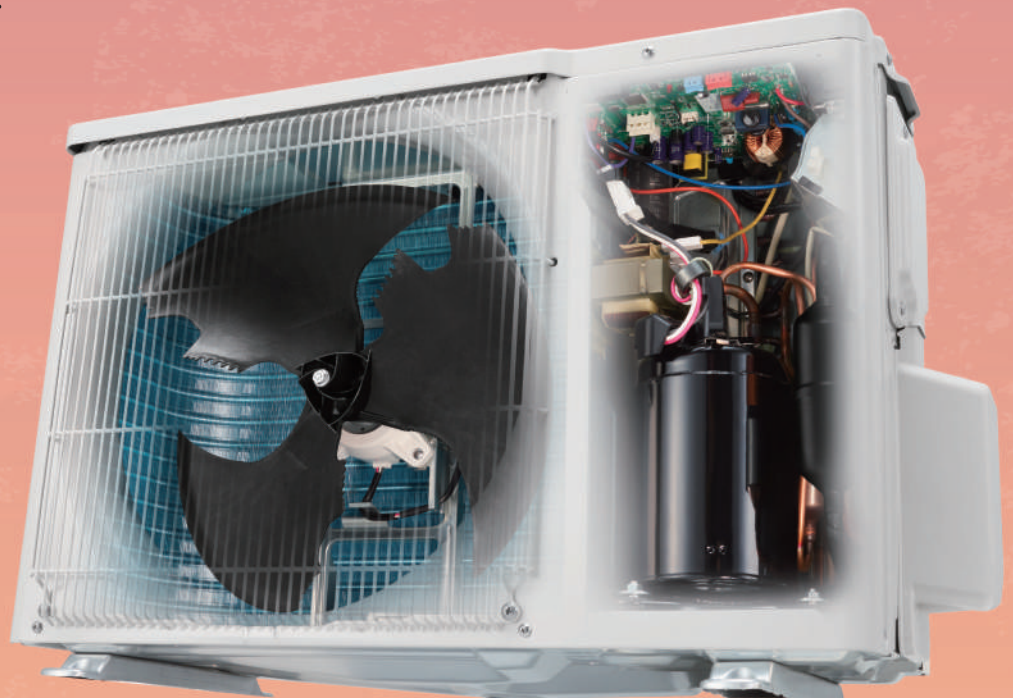



## MITSUBISHI ELECTRIC Compressor

The compressor is the heart of the Air Conditioner. Employing Mitsubishi Electric's proprietary technology, we are able to achieve both high efficiency and high power.

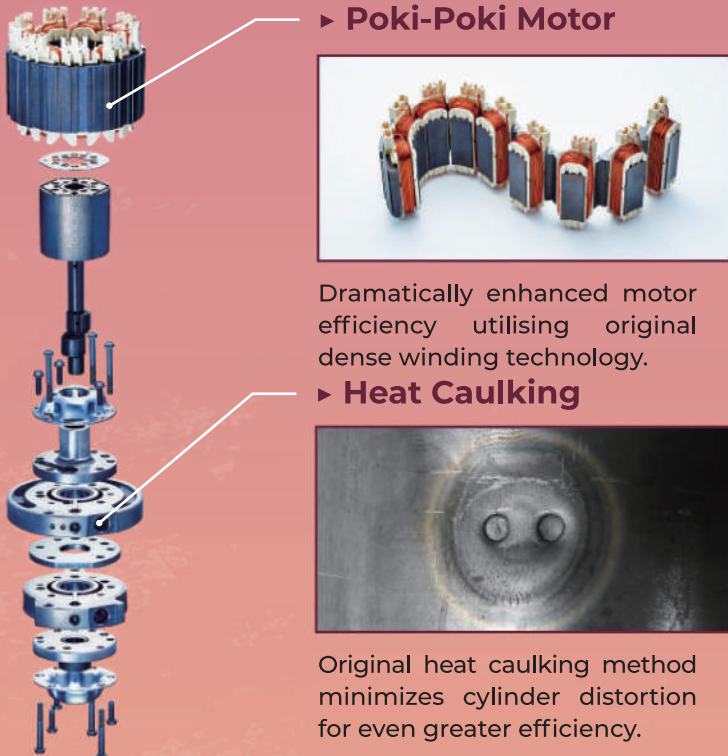

### ► Poki-Poki Motor



Dramatically enhanced motor efficiency utilising original dense winding technology.

### ► Heat Caulking



Original heat caulking method minimizes cylinder distortion for even greater efficiency.

## MITSUBISHI ELECTRIC Inverter Power Module

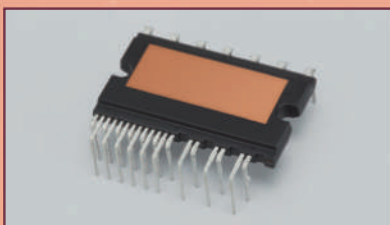

The Inverter Power Module is the brain of the Air Conditioner. It minimizes power consumption by adjusting the frequency.

## MITSUBISHI ELECTRIC Propeller Fan and DC Fan Motor

### ► Propeller Fan



Newly designed propeller fan maximizes airflow efficiency. It delivers the most air volume with the least noise.

### ► DC Fan Motor



A highly efficient DC Fan motor drives the fan of the outdoor unit. Efficiency is much higher than an equivalent AC motor.

# FAST COOLING

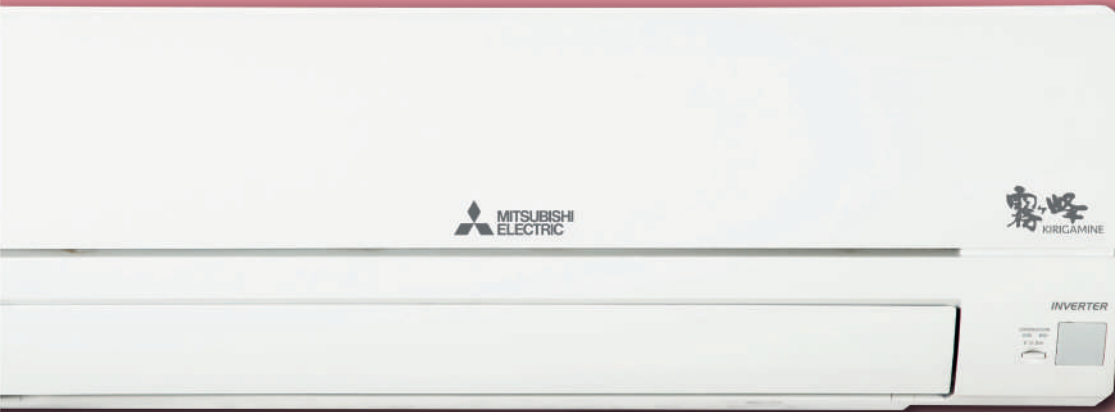

Mitsubishi Electric, a global leader in Air Conditioning, understands its customer requirement better than anyone else.

At Mitsubishi Electric, we invest great care in designing our product features, Instant relief from scorching heat is one such desire met successfully through the Fast Cooling feature in our Air Conditioners provided just at the click of a button.

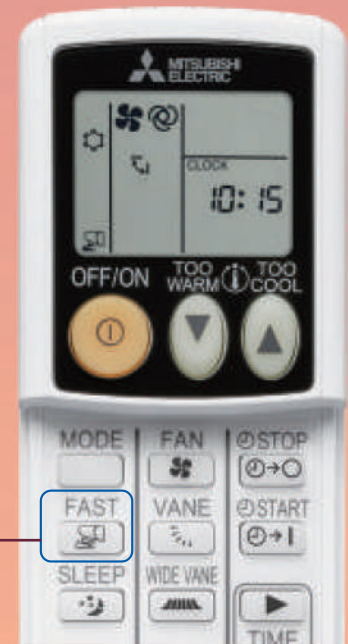



## 01 Fast Cooling Button

Once activated, this mode continues for 15 minutes.



Fast Cooling mode starts immediately with the push of a button. According to preference, air direction can be changed freely.

## 02 Thermography

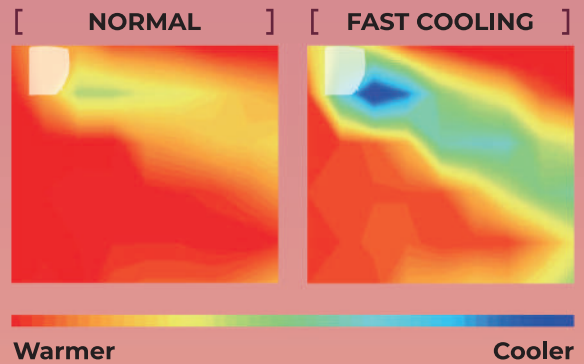

Quickly cools the room with the highest -volume, and low-temperature air blow at 2 min. after operation.

## 03 Compressor Frequency Image

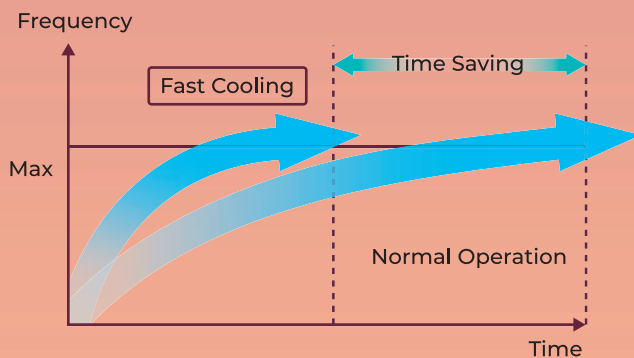

Pressing the Fast Cooling button makes the compressor reach its maximum frequency remarkably faster than in Normal Operation.

## 04 Air Outlet Temperature

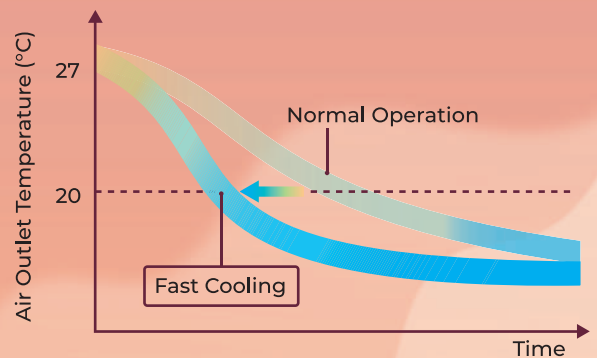

Lowers the air outlet temperature faster than Inverter Normal Operation.



# Micro Particle Catching Filter (PM 2.5) and High Density Filter

Effectively eliminates floating PM2.5 and smaller dust particles.

## 01 Micro Particle Catching Filter<sup>1</sup>

Effectively catches floating PM 2.5 particles to maintain clean air in the room.

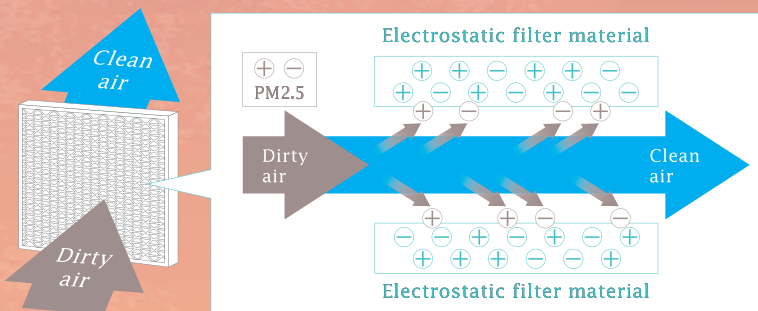

Electrostatic material removes PM 2.5 from the air and absorbs it when passing through the filter.



[ Model Name ]  
MAC-EMF515FT-E

## 02 High Density Filter<sup>2</sup>

High Density Filter can prevent smaller dust particles from entering inside Air Conditioners.

### ► Comparison of density of filters

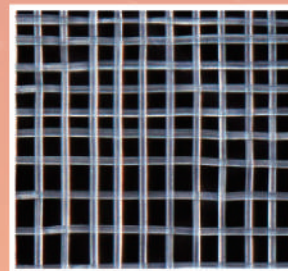

Standard Filter

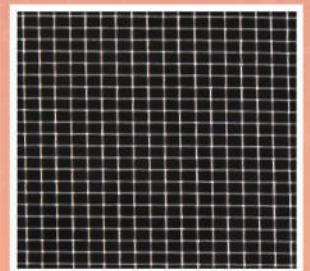

High Density Filter  
(Optional parts)

[ Model Name ] MAC-HDJ519FT-E  
MAC-HDH519FT-E

<sup>1</sup> 1 part available only

<sup>2</sup> Optional part

霧峰  
KIRIGAMINE

# Long Air Flow

Delivers substantial and comfortable airflow

Delivers Long and comfortable airflow upto 12m<sup>1</sup> suitable for living rooms.

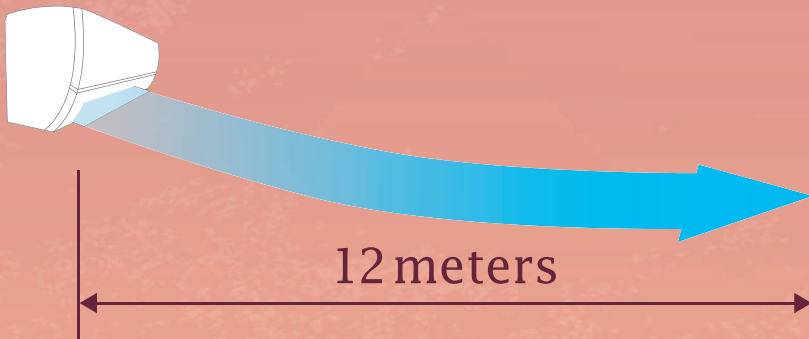

MITSUBISHI ELECTRIC launched the World's First\* Room Air Conditioner equipped with Cross Flow Fan in 1968.

\* Based on Euromonitor International research

## | Cross Flow Fan Technology



[ CROSS FLOW FAN ]

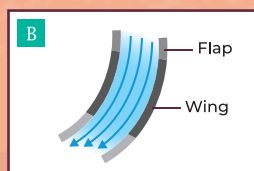
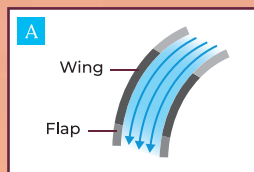

Our unique Cross-Flow Fan construction guides air smoothly along each rotating wing as it simultaneously intakes and expels air. This allows for highly efficient delivery of powerful and refreshing airflow.

<sup>1</sup>Available in MSY-RJS18/22

# Dual Barrier Coating

Dual Barrier Coating prevents dust and greasy dirt from getting into the Air Conditioner\*

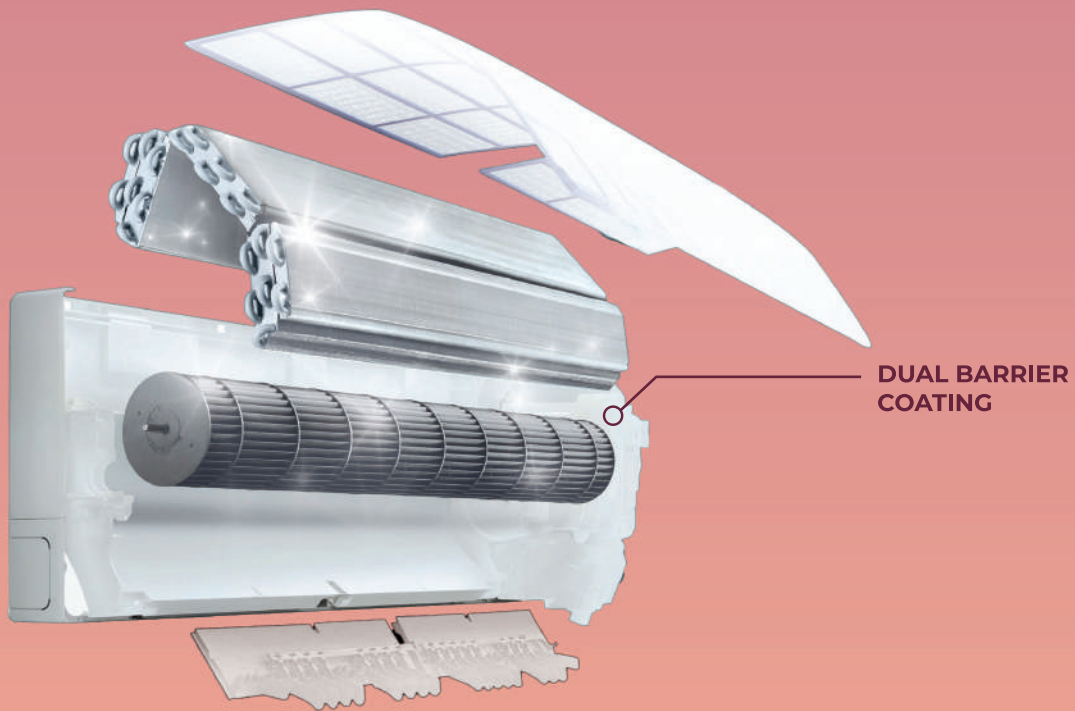

If the inside of your Air Conditioner gets dirty.

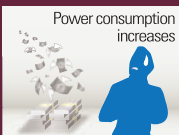



## State-of-the-art coating technology

### Dual Barrier Coating both types of dirt

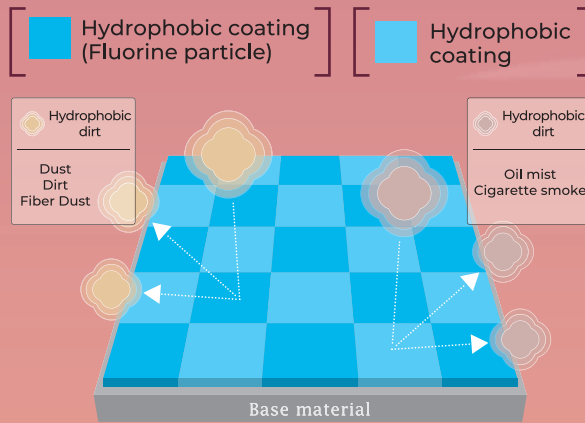

### Comparison of Dirt on Fan

#### [ FAN ]

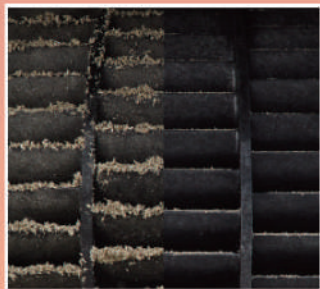

Image after 10 years | Dual Barrier Coating used

Dirt is generally classified into two groups. Dual Barrier Coating works as two-barrier coating with blended "fluorine particles" that prevent hydrophilic dirt penetration and "hydrophilic particles" that prevent hydrophobic dirt.

# Auto Vane Control

Up and Down / Left and Right

Auto vanes can be moved left and right, and up and down using the remote controller.

## Horizontal Airflow/Auto Vane Control

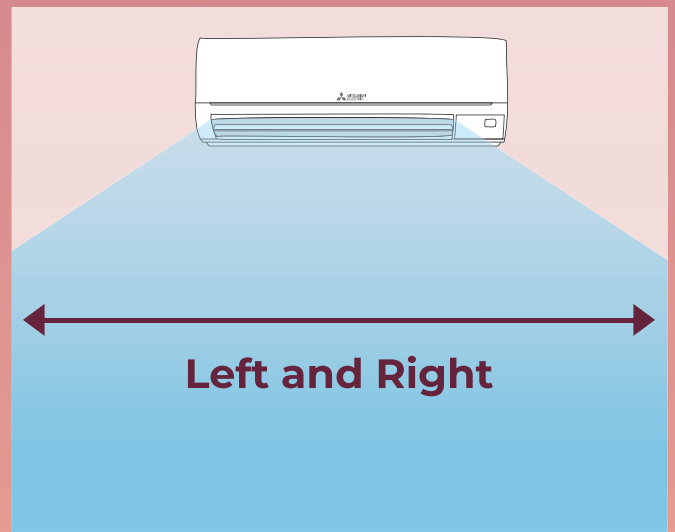
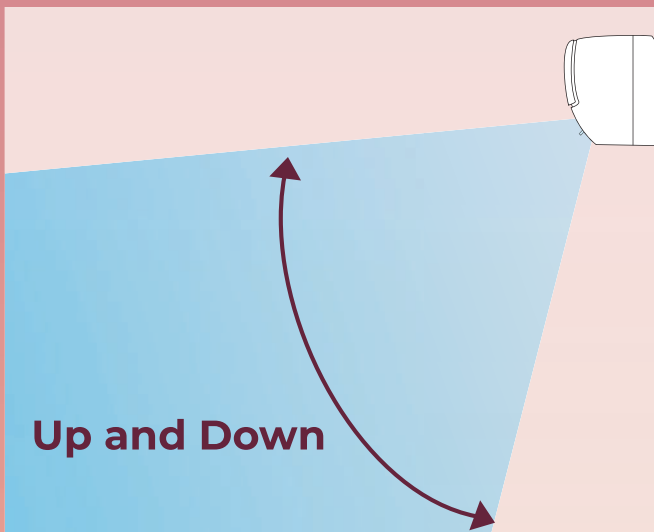

### Auto Vane Control Button

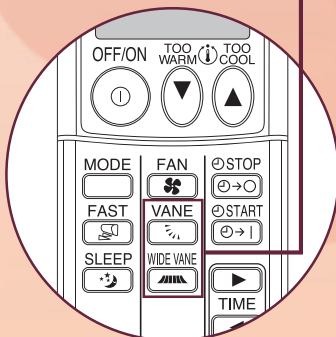

### Left and Right

Auto vanes can be set at 5 position and swing.

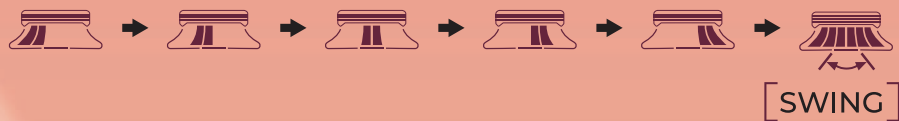

### Up and Down

Auto vanes can be set at 5 position and swing.

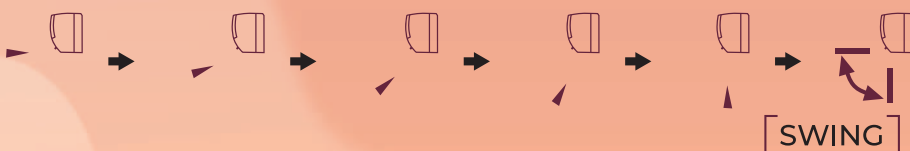



## Useful functions

### ▶ Sleep Mode

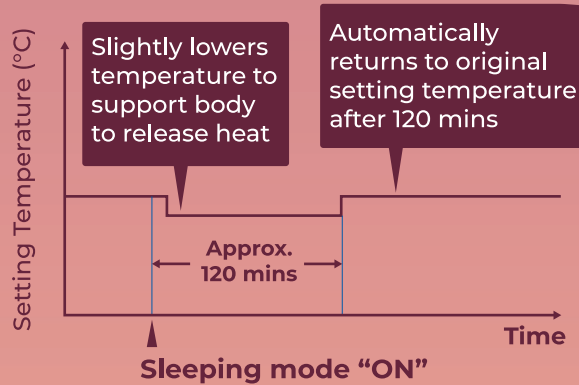

### ▶ Error code display



Error codes are displayed on the remote controller for troubleshooting

\*For details, please refer to the operating instructions.

# Kirigamine Series

## [ INDOOR UNIT ]

## [ REMOTE CONTROLLER ]

### ▶ MSY-RJS 13/15 VF

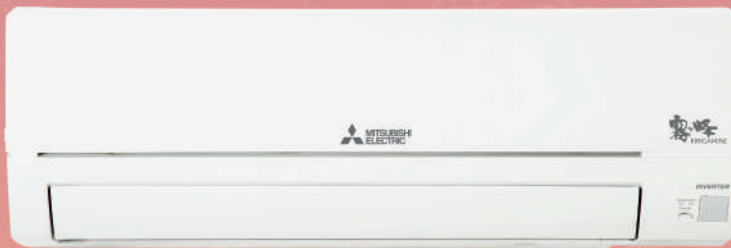

[ Luminous buttons ]



▶ H280 x W838 x D228 (mm)

### ▶ MSY-RJS 18/22 VF



[ Luminous buttons ]



▶ H305 x W921 x D263 (mm)



[ OUTDOOR UNIT ]

▶ MUY-RJS 13/15 VF



▶ H538 x W699 x D249 (mm)

▶ MUY-RJS 18 VF



▶ H550 x W800 x D285 (mm)

▶ MUY-RJS 22 VF



▶ H714 x W800 x D285 (mm)

# Specifications



Type	Cooling only					
Model name	Indoor unit		MSY-RJS13VF	MSY-RJS15VF	MSY-RJS18VF	MSY-RJS22VF
	Outdoor unit		MUY-RJS13VF	MUY-RJS15VF	MUY-RJS18VF	MUY-RJS22VF
Refrigerant			R32			
Power supply	Source		Single phase, 230V, 50Hz			
			Outdoor power supply			
Capacity	Rated (Min-Max)	kW	3.6(0.9-3.7)	4.2(1.2-4.2)	5.2(1.5-5.7)	6.6 (1.6-6.7)
	TR	TR	1.00	1.25	1.50	1.9
Total Input	Rated (Min-Max)	kW	1.27(0.30-1.35)	1.44(0.35-1.59)	1.68(0.35-2.04)	2.01 (0.34-2.20)
ISEER			4.15	4.23	4.23	4.22
SPL	Indoor unit (Quiet-Lo-Med-Hi-SHi)	dB(A)	22-28-36-40-43	26-31-37-42-46	26-33-40-44-49	27-37-41-45-51
Air Volume	Indoor unit (Quiet-Lo-Med-Hi-SHi)	CFM	190-247-331-397-452	197-274-352-419-471	230-297-392-459-569	300-399-487-576-660
Operating Current	Rated	A	6	6.7	7.5	9.1
Indoor unit	Dimensions (H x W x D)	mm	280x838x228	280x838x228	305x923x262	305x923x262
	Weight	kg	8.5	8.5	11.5	12.5
Outdoor unit	Dimensions (H x W x D)	mm	538x699x249	538x699x249	550x800x285	714x800x285
	Weight	kg	21	24.5	31.5	37.0
Ext.Piping	Diameter Liquid	mm (inches)	6.35(1/4)	6.35(1/4)	6.35(1/4)	6.35(1/4)
	Diameter Gas	mm (inches)	9.52(3/8)	9.52(3/8)	12.7(1/2)	12.7(1/2)
	Max.Length Out-In	m	20	20	20	30
	Max.Height Out-In	m	12	12	12	15
Star Rating			4 Star	4 Star	4 Star	4 Star

Pre filter	ANTI-MOLD/HIGH DENSITY FILTER (Option)					
Air cleaning filter			MICROPARTICLE CATCHING FILTER			
Timer			12h	12h	24h	24h
Vertical Swing	Auto		-	-	○	○
	Manual		○	○	-	-
Control wiring (Copper)	ODU to IDU	Core No. x Sq.mm	4C x 1.0	4C x 1.0	4C x 1.0	4C x 1.0
Power cable (Copper)	To ODU	Core No. x Sq.mm	3C x 1.0	3C x 1.0	3C x 1.0	3C x 2.0
ODU Breaker Size	To ODU	A	10	10	10	16

## Rating conditions:

**Cooling - Indoor:** 27°C (80°F) DB, 19°F (66°F) WB, **Outdoor:** 35°C (95°F)

Refrigerant piping length (one-way): 5.0m (16.4ft)

Total input based on the indicated voltage (indoor/outdoor): 1 phase 230V 50Hz.

# Functions and Features

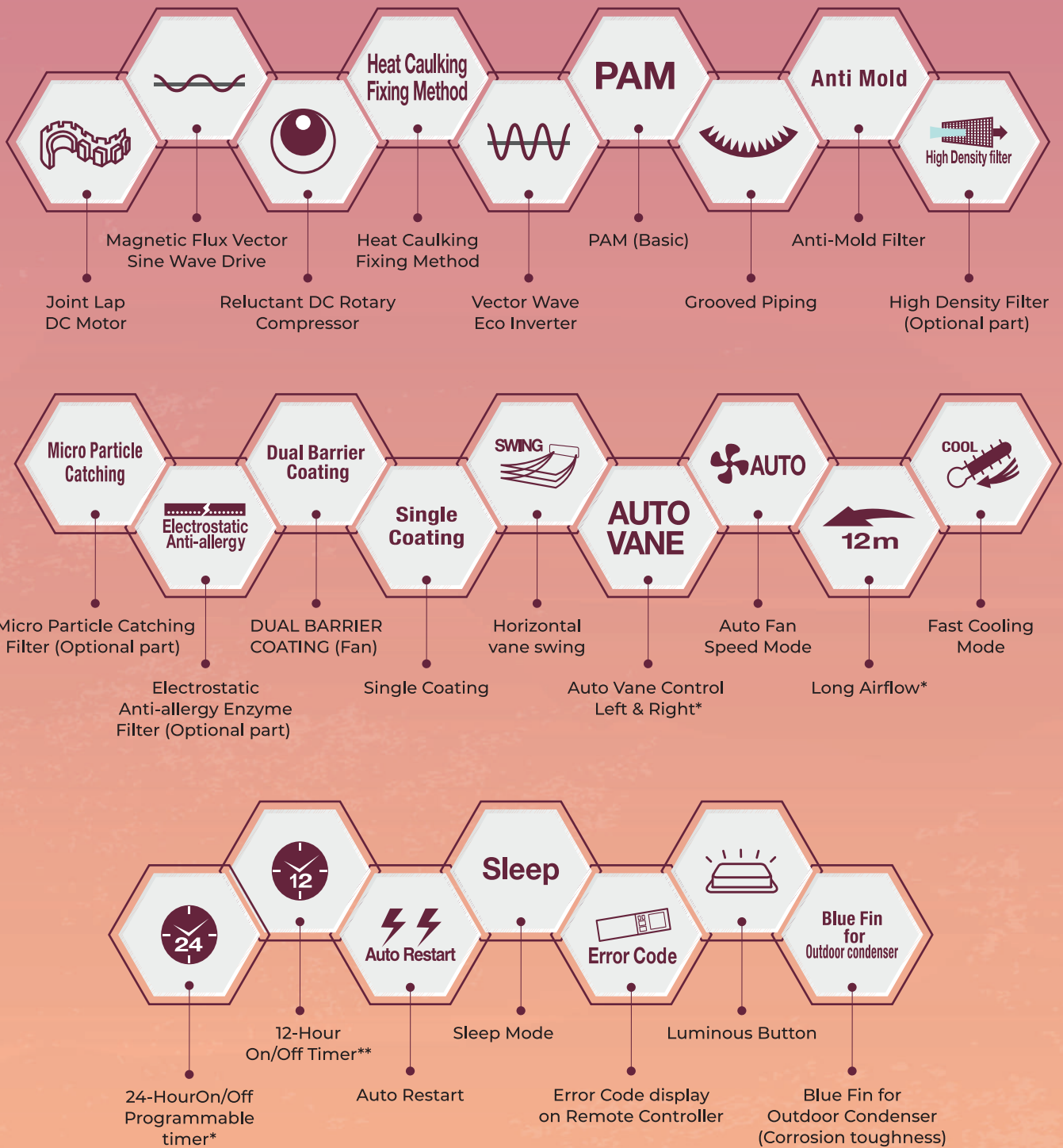

\*Only for MSY-RJS18/22VF \*\*Only for MSY-RJS13/15VF



**SUPREMEY  
POWERFUL ACs FOR  
BIGGER ROOMS**



**JR**  
Series

(Inverter Cooling Only)

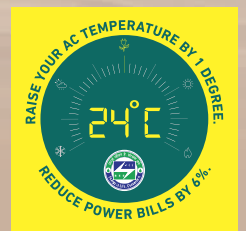

# Mitsubishi Electric Inverter Technology

The JR Series features advanced inverters that utilize Mitsubishi Electric's cutting edge technology, developed worldwide through many years of experience. We have achieved powerful cooling with high energy efficiency to bring you optimal comfort.



## Inverter Power Module



### Inverter Power Module

The Inverter Power Module is the brain of the air conditioner. It minimizes power consumption by adjusting the frequency. The IPM is developed by MELCO.

## Mitsubishi Electric Propeller Fan And DC Fan Motor



### Propeller Fan

Newly designed propeller fan maximizes airflow efficiency. It delivers the most air volume with the least noise.



### DC Fan Motor

A highly efficient DC Fan motor drives the fan of the outdoor unit. Efficiency is much higher than an equivalent AC motor.

## Mitsubishi Electric Compressor

The compressor is the heart of the air conditioner. Employing Mitsubishi Electric's proprietary technology, we are able to achieve both high efficiency and high power.



### Poki-Poki Motor

Dramatically enhanced motor efficiency utilizing original dense winding technology. 28% more wire as compared to conventional motor.



### Heat Caulking

Original heat caulking method minimizes cylinder distortion for even greater efficiency.

# Fast Cooling

Mitsubishi Electric's Fast Cooling brings instant refreshment & relief from the scorching heat and provides a comfortable environment.

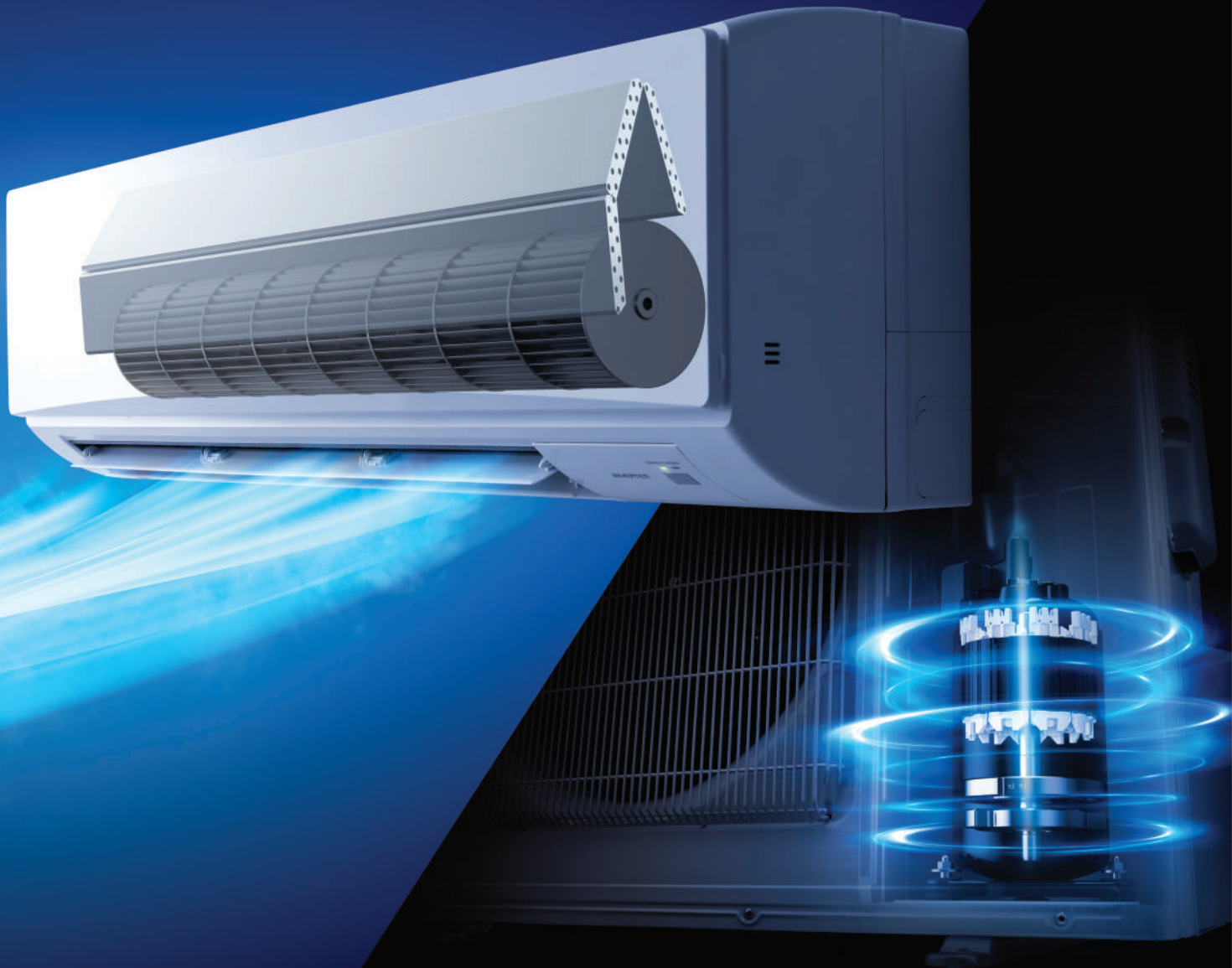

### 01 Compressor Frequency Image

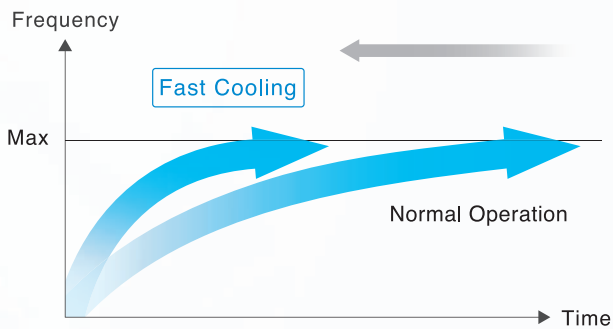

Pressing the Fast Cooling button makes the compressor reach its maximum frequency remarkably faster than in normal operation.

### 02 Air Outlet Temperature

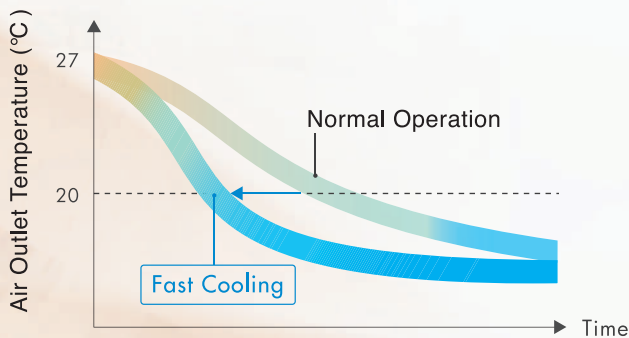

Lowers the air outlet temperature faster than in normal operation.

### 03 Thermography

Quickly cools the room using the highest-volume and low-temperature airflow settings, within 2 minutes of operation.

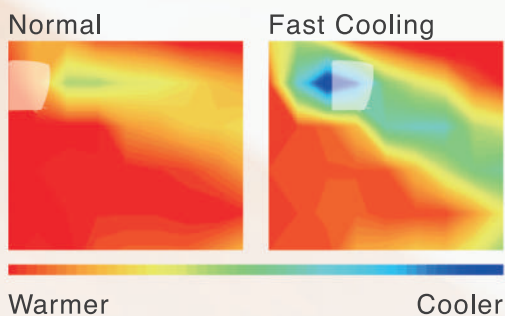

### 04 Fast Cooling Button

Fast Cooling mode starts immediately with a push of the button. According to preference, air direction can be changed freely.

**Fast Cooling Once Activated Continues For 15 Minutes.**

The image shows a Mitsubishi remote control with a digital display showing '15:15'. The 'FAST' button is highlighted with a blue border. Below the main text, there is a smaller image of the remote control with various buttons labeled: MODE, FAN, STOP, FAST VANE, VANE, START, SLEEP, WEE VANE, TIME, and LOCK.

## Long Airflow

Delivers substantial and comfortable airflow

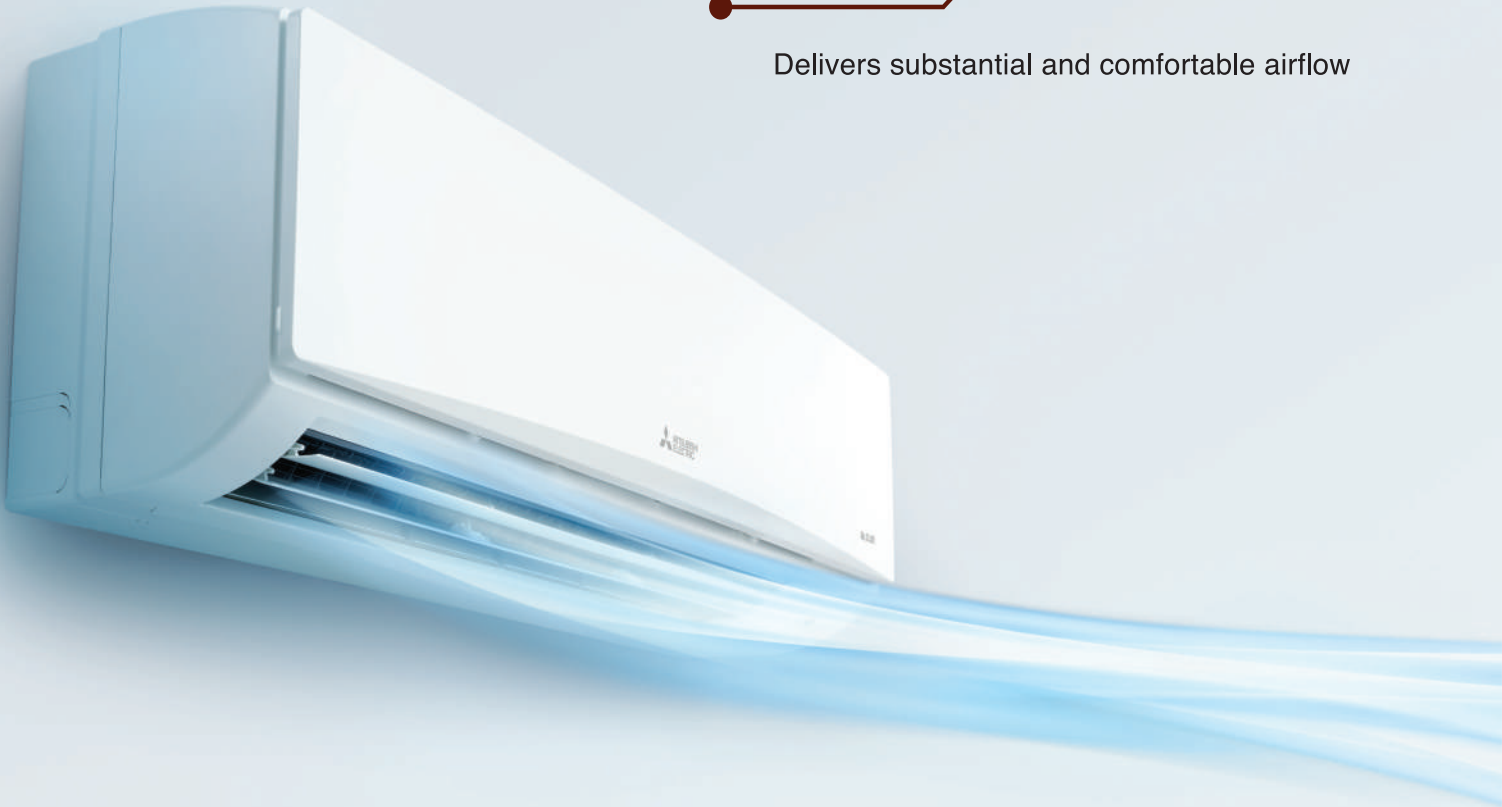

Delivers comfortable airflow up to 12 meters. Suitable for even large living rooms.

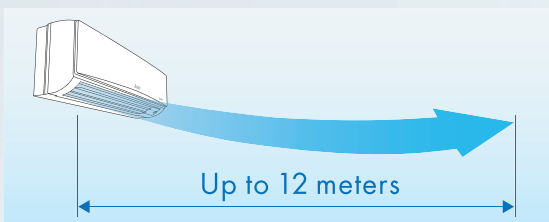

It's available when air direction is horizontal and fan speed is S-Hi.

### CROSS FLOW FAN TECHNOLOGY

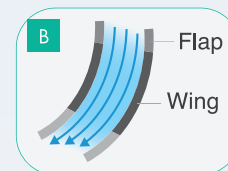
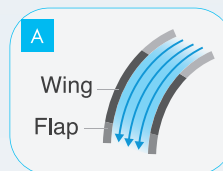

Our unique Cross Flow Fan construction guides air smoothly along each rotating wing as it simultaneously intakes and expels air. This allows for highly efficient delivery of powerful and refreshing airflow.



MITSUBISHI ELECTRIC launched the World's First\* Room Air Conditioner equipped with Cross Flow Fan in 1968.

\*Based on Euromonitor International research

# Dual Barrier Coating

State-of-the-art Dual Barrier Coating technology prevents rust and greasy dirt from getting into the air conditioner.

## Dual Barrier repels both types of dirt

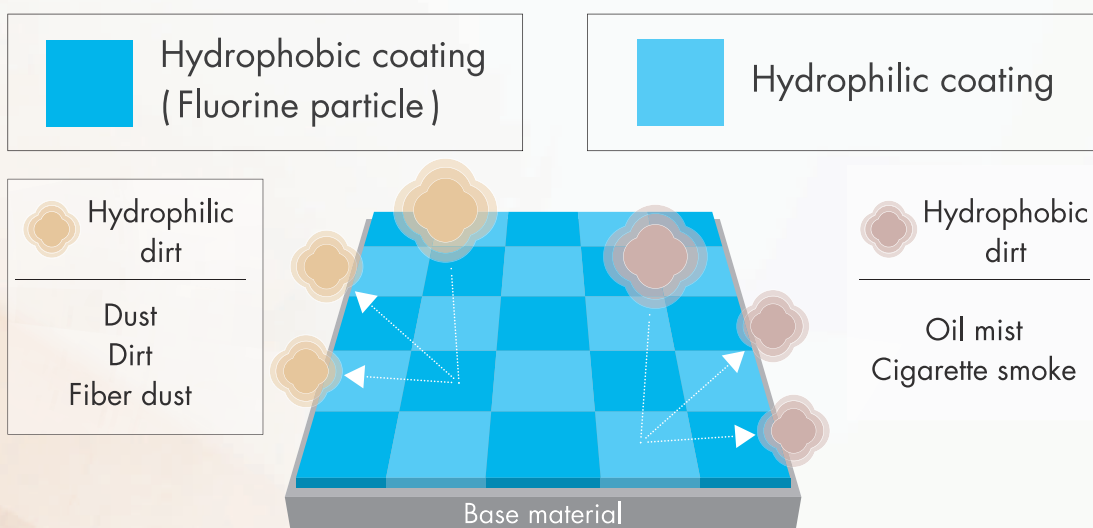

Dirt is generally classified into two groups.

Dual Barrier Coating works as a barrier coating for both, with blended “fluorine particles” that prevent hydrophilic dirt penetration and “hydrophilic particles” that prevent hydrophobic dirt.

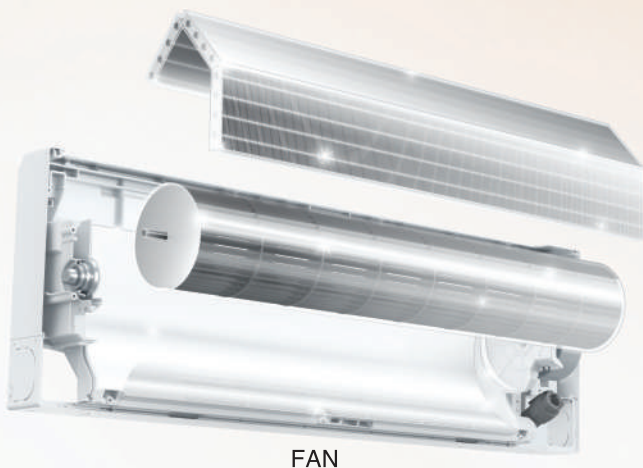

FAN



Image after 10years

Dual Barrier Coating used

# Micro Particle Catching Filter and High Density Filter\*

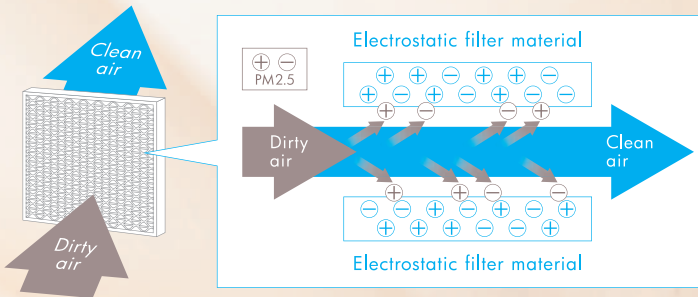

Effectively catches floating PM 2.5 particles to maintain clean air in the room.

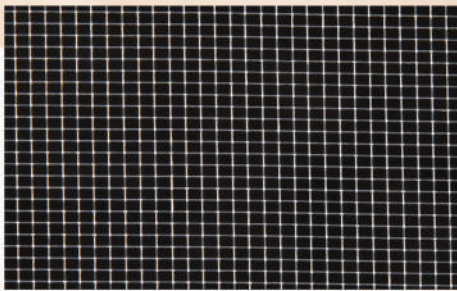

High Density Filter

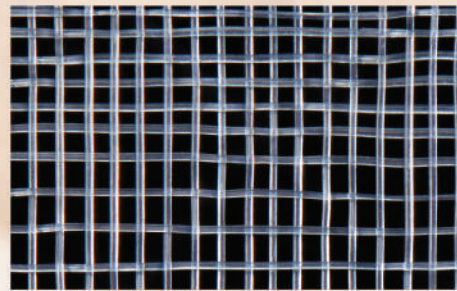

Standard Filter

High Density Filter can prevent smaller dust from entering the inside of air conditioner.

# Autovane Control Up And Down/Left And Right

## Horizontal Airflow/Auto Vane Control



### Up & Down

Auto vanes can be set at 5 positions and swing.

Auto vane can be moved to left & right, up & down



SWING

### Left & Right

Auto vanes can be set at 6 position and swing.



SWING

Auto Vane Control Button



\* Optional



## MSY-JR Series

### FUNCTIONS & FEATURES

- |  |   |   |
|--|---|---|
|  Joint Lap DC Motor                           |  Computerised Dehumidification                         |  Fuzzy Logic "I Feel"                      |
|  PAM (Basic)                                 |  Electronic Metal Housing                             |  Battery Replacement Indicator            |
|  Grooved Piping                             |  24 Hour Timer                                       |  12m Long Airflow                        |
|  Auto Vertical Vane (JR-30/36)              |  Self-diagnosis (IDU Blinking)                       |  Auto Restart                            |
|  Auto Horizontal Vane                       |  Electrostatic Anti-allergy Enzyme Filter (Optional) |  Blue Fin Condenser Toughness (JR-30/36) |
|  Anti-rust                                  |  Dual Barrier Coating (FAN)                          |  IDU Anti-corrosion Coating              |
|  Powerful Cool (JR-22/30)                   |  Double Horizontal Vane (JR-30/36)                   |  Sleep Mode (JR-36)                      |
|  Anti-Mold Filter                           |  Auto Fan Speed Mode                                 |  Error Code Display on RC (JR-36)        |
|  High Density Filter (Optional in JR-30/36) |  DC Fan Motor  |  Fast Cooling (JR-36)                    |
|  Micro Particle Catching Filter (Optional)  |  Econo Cool (JR-30)                                  |   |

# Remote Controller

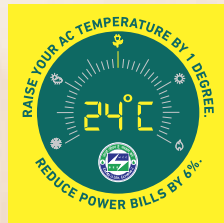

24°C DEFAULT SETTING



LUMINOUS BUTTONS



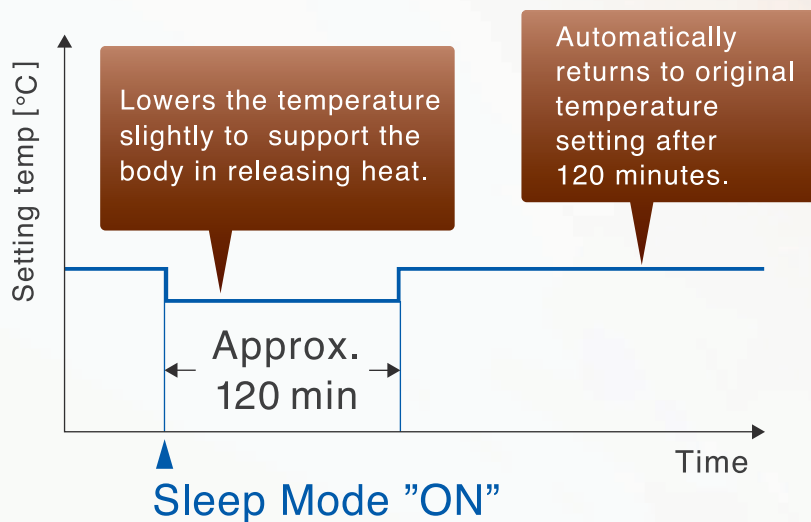

ERROR CODE DISPLAY

## SLEEP MODE



# MSY-JR Series Specifications

Type	Cooling Only				
Model Name	Indoor Unit		MSY-JR22VF	MSY-JR30VF	MSY-JR36VF
	Outdoor Unit		MUY-JR22VF	MUY-JR30VF	MUY-JR36VF
Refrigerant	R32				
Power Supply	Source	Single phase, 230V, 50Hz Outdoor power supply			
Capacity	Rated (Min-Max)	kW	6.6 (1.6-6.7)	8.2 (2.4-9.2)	10.0 (2.9-10.2)
	TR	TR	1.9	2.5	3.0
Total Input	Rated (Min-Max)	kW	2.01 (0.34-2.20)	2.53 (0.48-3.34)	3.45(0.60-3.50)
ISEER			4.22	4.36	4.00
SPL	Indoor Unit (Quiet-Lo-Med-Hi-SHi)	dB(A)	29-37-41-45-51	30-38-45-51	32-38-43-49-53
Air Volume	Indoor Unit (Quiet-Lo-Med-Hi-SHi)	CFM	254-335-417-537-671	307-413-519-735	360-508-621-784-935
Operating Current	Rated	A	9.2	11.6	15.3
	Max	A	12.5	16.5	16.7
Indoor Unit	Dimensions (H x W x D)	mm	305x923x250	325x1100x238	365x1175x295
	Weight	kg	12.5	15.0	20
Outdoor Unit	Dimensions (H x W x D)	mm	714x800x285	880x840x330	880x840x330
	Weight	kg	37.0	48.5	49
Ext. Piping	Diameter Liquid	mm (inches)	6.35(1/4)	6.35(1/4)	6.35(1/4)
	Diameter Gas	mm (inches)	12.7(1/2)	12.7(1/2)	15.88(5/8)
	Max.Length Out-In	m	30	30	30
	Max.Height Out-In	m	15	15	15
Star Rating					

Pre Filter	ANTI-MOLD/HIGH DENSITY FILTER (Option only for JR36)				
Air Cleaning Filter	ELECTROSTATIC ANTI-ALLERGY ENZYME FILTER (Option), MICROPARTICLE CATCHING FILTER(Option)				
Timer			12h	24h	24h
Vertical Swing	Auto		-	○	○
	Manual		○	-	-
Wide and Long			-	○	-
"Control Wiring (Copper)"	ODU to IDU	Core No. x Sq.mm	4C x 1.0	4C x 1.0	4C x 1.0
"Power Cable (Copper)"	To ODU	Core No. x Sq.mm	3C x 2.0	3C x 2.5	3C x 2.5
"ODU Breaker Size"	To ODU	A	16	20	20



# MSZ-HP SERIES

(Inverter Heat Pump)

## SUMMER



**46°C**

APR

S	M	T	W	T	F	S
						1 2
3	4	5	6	7	8	9
10	11	12	13	14	15	16
17	18	19	20	21	22	23
24	25	26	27	28	29	30

## WINTER



**-10°C**

DEC

S	M	T	W	T	F	S
						1 2
3	4	5	6	7	8	9
10	11	12	13	14	15	16
17	18	19	20	21	22	23
24	25	26	27	28	29	30



**FOR THE HOTTEST SUMMER DAY.  
AND THE COLDEST WINTER NIGHT.**

\* 4 Star and 3 Star also available.

# FEATURES

01

## Advanced inverter control-

Efficient operation all the time  
Mitsubishi Electric inverters ensure superior performance, including the optimum control of operational frequency. As a result, optimum power is applied in all cooling / heating ranges and maximum comfort is achieved while consuming minimal energy. Fast, comfortable operation at an amazingly low running cost - that's the Mitsubishi Electric promise.



02

## R410A

Refrigerants that contain hydrochlorofluorocarbons such as HCFC-R22 with chlorine are a contributing factor to ozone layer depletion. R410A- a chlorine-free, non-inflammable, environment friendly and energy efficient alternative to R22, due to its pseudoazeotropic characteristics.

	Composition	Ozone-depletion potential factor*	Toxicity	Stability
NEW REFRIGERANT	Non-uniform boiling point composite refrigerant			
<b>R410A</b>	<b>(HFC:R32/R125=50:50WT%)</b>	<b>0</b>	<b>NON</b>	<b>GOOD</b>
CURRENT REFRIGERANT	Single component refrigerant			
<b>R22</b>	<b>(HCFC:R22=100WT%)</b>	<b>0.05</b>	<b>NON</b>	<b>GOOD</b>

\*Relative value when CFC is considered as 1



03

## Cleaning-free, Pipe Reuse Technology\*\*

### MITSUBISHI ELECTRIC'S SOLUTION FLUSH, VACUUM & INSTALL

Mitsubishi Electric's exclusive cleaning-free, Pipe-reuse technology allows you to reuse existing R22 refrigeration piping even when installing a new R410A model

Our R410A Inverter-driven models are the first in the industry to use hard alkyl benzene (HAB) oil-a unique refrigerant oil that degrades very slowly-for refrigeration. Employing our exclusive cleaning-free technologies such as a specially developed high-efficiency oil separator and optimum distribution of heat exchangers to prevent oil stagnation.

#### ORIGINAL HAB OIL

- No-special cleaning required
- Re-use existing pipes
- Cleaning/Purging process
- Special tools (Oil trap kit)
- Higher working pressure

\*\*Please consult MEI Team before Re - use of pipe



04

## Long airflow

Use this function to ensure the airflow circulates to areas far across the room. Press Long Airflow icon on the remote controller to extend reach up to as far as 12 meters from the unit.

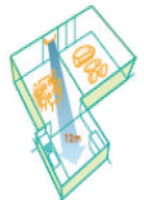

05

## IDU anti-corrosion coating

In India market, gas leakage occurs frequently from bends. For preventing it, MSZ-HP Series puts "anti-corrosion coating".

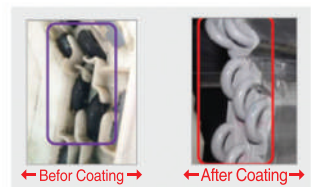

06

## Silver-ionized Air Purifier Filter

The high performance filter is attached as optional. Captures the bacteria, pollen and other allergens in the air and neutralises them.





07

## Anti-rust

All outdoor cabinets have been treated with special anti-rust painting.



## SPECIFICATIONS

Type		Heat pump				
Model name	Indoor unit	MSZ-HP13VA	MSZ-HP18VA	MSZ-HP24VA		
	Outdoor unit	MUZ-HP13VA	MUZ-HP18VA	MUZ-HP24VA		
Refrigerant	R410A					
Power supply	Source	Single phase, 230V, 50Hz				
		Indoor power supply				
Cooling	Capacity	Rated (Min-Max)	kW	3.15 (1.4-3.50)	5.20 (1.7-5.60)	7.10 (1.8-7.10)
		TR	TR	1.00	1.50	2.00
	Total Input	Rated (Min-Max)	kW	1.04 (0.36-1.27)	1.57 (0.42-1.95)	2.33 (0.30-2.33)
	ISEER			3.62	4.63	4.20
	SPL	Indoor unit (Lo-Med-Hi-SHi)	dB(A)	22-31-38-45	28-36-40-45	33-38-44-50
	Air Volume	Indoor unit (Lo-Med-Hi-SHi)	CFM	134-204-278-386	331-428-524-620	352-428-524-696
	Operating Current	Rated	A	5.1	7.0	10.3
Heating	Capacity	Rated (Min-Max)	kW	3.60 (1.1-4.10)	5.40 (1.4-6.50)	8.10 (1.5-8.50)
		TR	TR	1.00	1.50	2.00
	Total Input	Rated (Min-Max)	kW	0.995 (0.37-1.2)	1.48 (0.27-2.03)	2.44 (0.29-2.70)
	SPL	Indoor unit (Lo-Med-Hi-SHi)	dB(A)	23-30-37-44	27-34-41-47	33-38-44-49
	Air Volume	Indoor unit (Lo-Med-Hi-SHi)	CFM	122-195-270-366	311-428-524-620	366-448-573-710
	Operating Current	Rated	A	4.7	6.6	10.8
	Indoor unit	Dimensions (H x W x D)	mm	290x799x232	305x923x250	
Weight		kg	9	13		
Outdoor unit	Dimensions (H x W x D)	mm	538x699x249	550x800x285	880x840x330	
	Weight	kg	25.0	36	55	
	Breaker Size (MCB required)	A	10	16	16	
Ext.Piping	Diameter Liquid	mm (inches)	6.35(1/4)	6.35(1/4)	9.52(3/8)	
	Diameter Gas	mm (inches)	9.52(3/8)	12.7 (1/2)	15.88(5/8)	
	Max.Length Out-In	m	20	20	30	
	Max.Height Out-In	m	12	12	15	
Star Rating						
Pre filter	ANTI-MOLD					
Air cleaning filter	Silver Ionised Air Purifier Filter (Option)					
Timer			12hr	12hr	12hr	
Vertical Swing	-					
Wide and Long	-					
"Control wiring (Copper)"	IDU to ODU	Core No. x Sq.mm	4C x 1.0	4C x 2.0	4C x 2.0	
"Power cable (Copper)"	To IDU	Core No. x Sq.mm	3C x 1.0	3C x 2.0	3C x 2.0	
"Breaker Size"	To IDU	A	10	16	16	

**Compact, High Performance indoor and outdoor units and advanced inverter technologies provide superior energy savings and comfort in all rooms.**

**High energy efficient air conditioners with advanced Inverter Technology provides superior comfort round the season.**

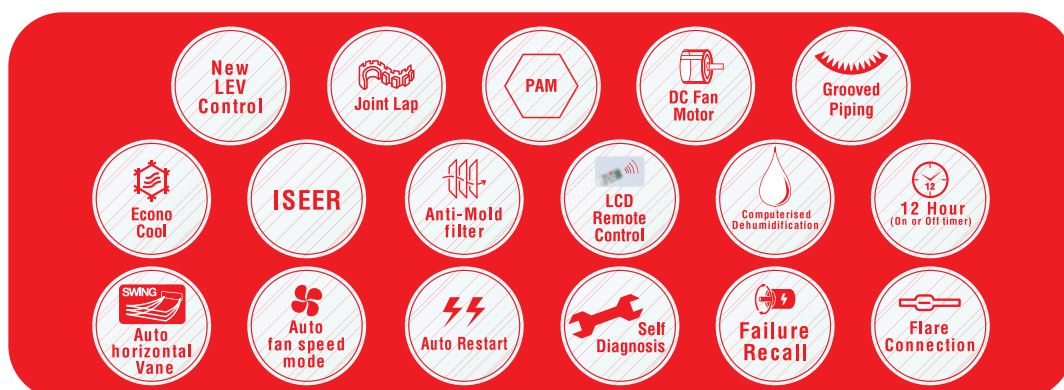



# YJP Series

(Inverter Cooling Only)

**Mr. SLIM**  
New Range of Airconditioners



---

CREATING  
YOUR COMFORT

---

# MITSUBISHI ELECTRIC Inverter Technology

JP Series features advanced inverters that utilize MITSUBISHI ELECTRIC's cutting edge technology, developed worldwide through many years of experience. We have achieved powerful cooling with high energy efficiency, to bring you optimal comfort.

## MITSUBISHI ELECTRIC

### Inverter Power Module

The Inverter Power Module is the brain of the air conditioner. It minimizes power consumption by adjusting the frequency. IPM is developed by MELCO

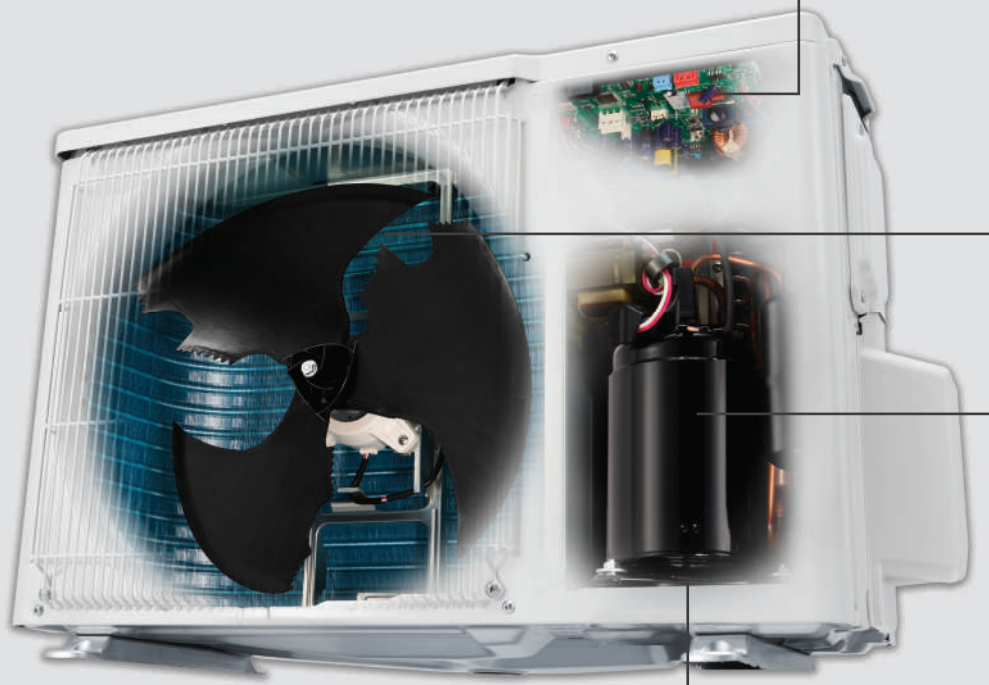
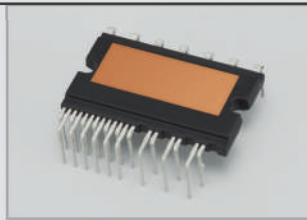

## MITSUBISHI ELECTRIC Propeller Fan and DC Fan Motor

### Propeller Fan



Newly designed propeller fan maximizes airflow efficiency. It delivers the most air volume with the least noise.

### DC Fan Motor



A highly efficient DC Fan motor drives the fan of the outdoor unit. Efficiency is much higher than an equivalent AC motor.

## MITSUBISHI ELECTRIC Compressor

The compressor is the heart of the air conditioner. Employing MITSUBISHI ELECTRIC's proprietary technology, we are able to achieve both high efficiency and high power.



### Poki-Poki Motor

Dramatically enhanced motor efficiency utilising original dense winding technology. 28% more wire on compared to conventional motor



### Heat Caulking

Original heat caulking method minimizes cylinder distortion for even greater efficiency.



## **EASY MAINTENANCE**

### **DUAL BARRIER COATING**

Dual Barrier Coating and single coating prevent dust and greasy dirt from getting into the air conditioner

**Patented technology by Mitsubishi Electric - 1<sup>st</sup> in Industry**

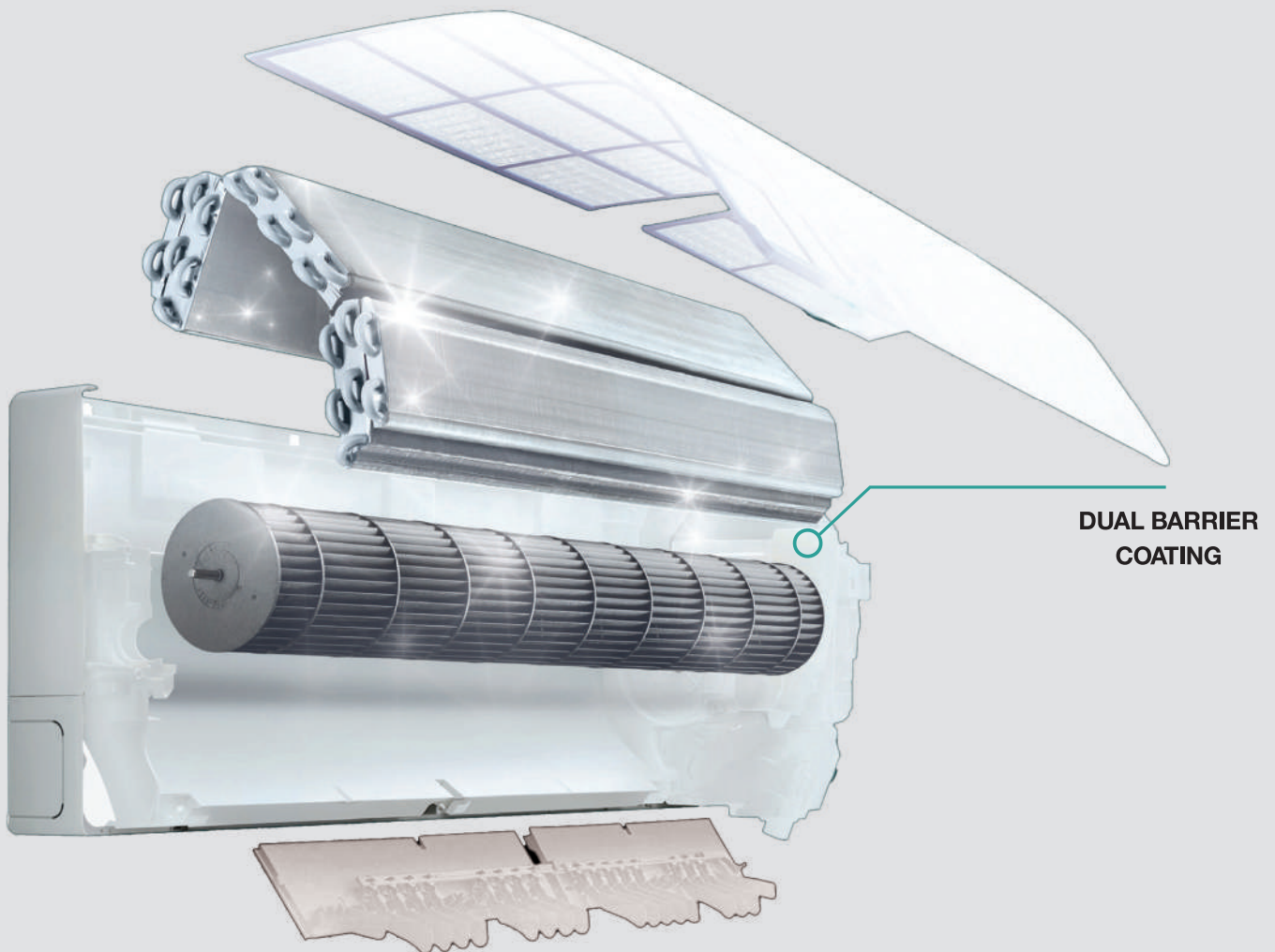

# Dual Barrier Coating

Kept clean for more comfortable room

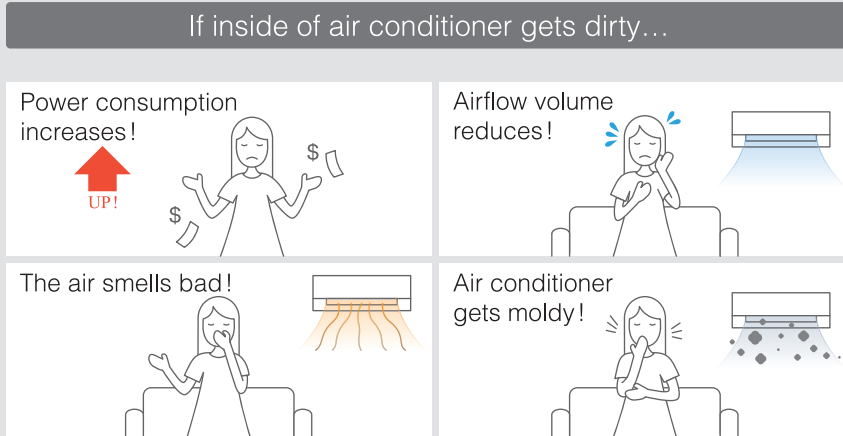

If dirt is left to accumulate it can lead to a “loss of energy conservation due to lower operating efficiency” or “cause the air coming from the air conditioner to smell bad”.

Applying the Dual Barrier Coating to the inner surface of the air conditioner prevents dirt from getting in and thus eliminates such problems.

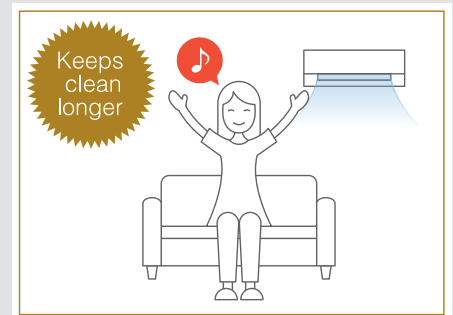

## State-of-the-art coating technology

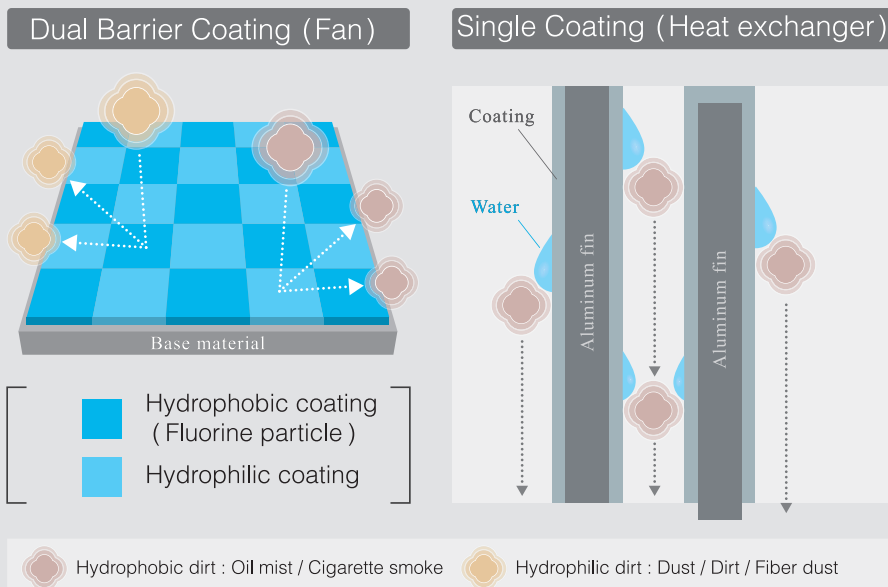

# IDU Anti-corrosion Coating



Before Coating

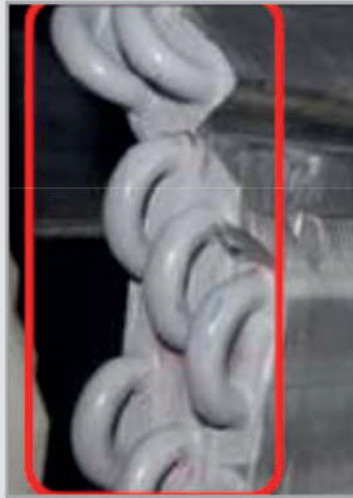

After Coating

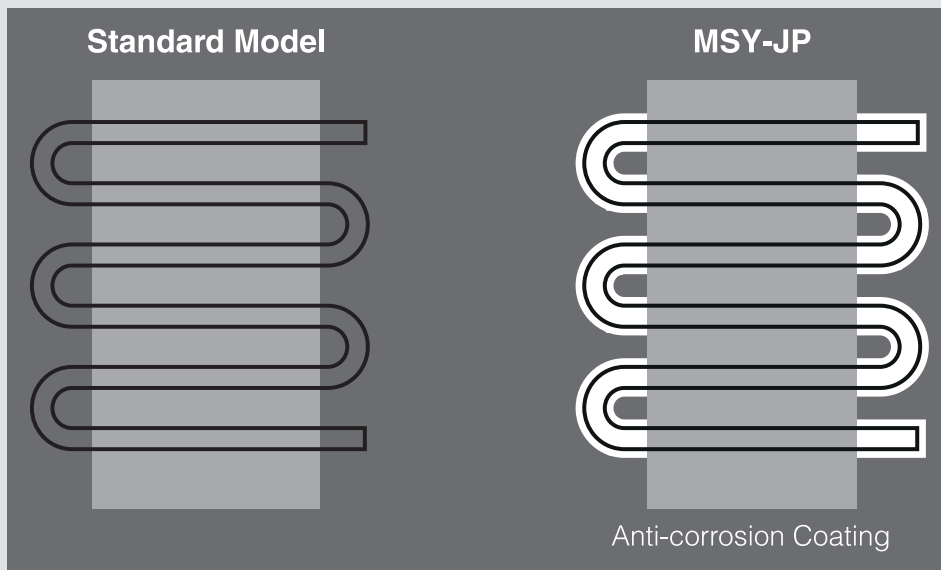

'Anti corrosion Coating' is done to prevent gas leakage from AC coil bend which is very frequent in Indian market conditions

## Comparison of dirt on Fan

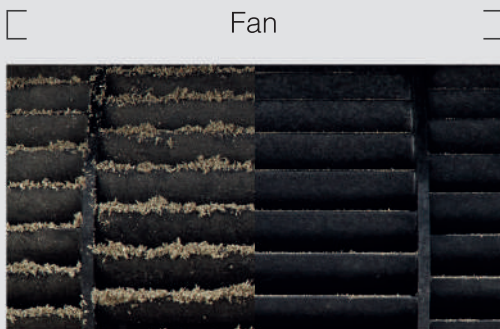

Image after 10years      Dual Barrier Coating used

Dirt is generally classified into two groups. Dual barrier coating works as a two barrier coating with blended "fluorine particles" that prevent hydrophilic dirt penetration and "hydrophilic particles" that prevent hydrophobic dirt.

# AIR QUALITY



MICROPARTICLE CATCHING FILTER  
(OPTIONAL)

**Effectively eliminates PM2.5**

Projects air flow up to 12 meters.  
Suitable even for living rooms.

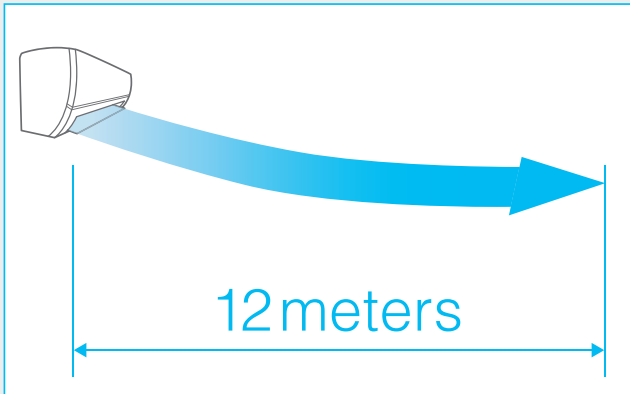

---

Model comparison

---

- MSY-JP 10/13/15/18VF ..... 8m
  - MSY-JP22VF ..... 12m
- 

**|** Cross Flow Fan Technology



[ Cross Flow Fan ]

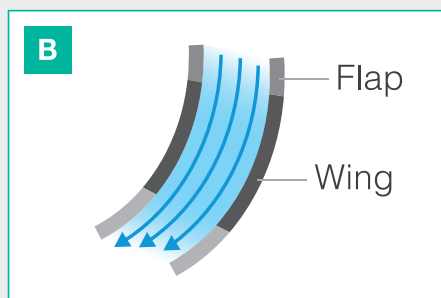
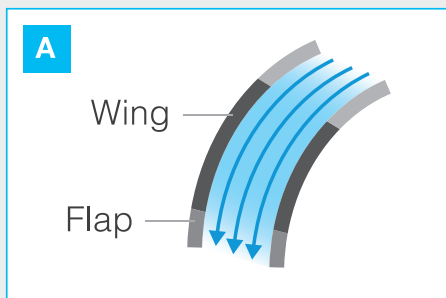

Our unique Cross Flow Fan construction guides air smoothly along each rotating wing as it simultaneously intakes and expels air. This allows for highly efficient delivery of powerful and refreshing airflow.

# LONG AIR FLOW

Delivers substantial and comfortable airflow



**MITSUBISHI ELECTRIC launched the World's First\* Room Air Conditioner equipped with Cross Flow Fan in 1968.**

\*Based on Euromonitor International research

## PM2.5 Removal Efficiency

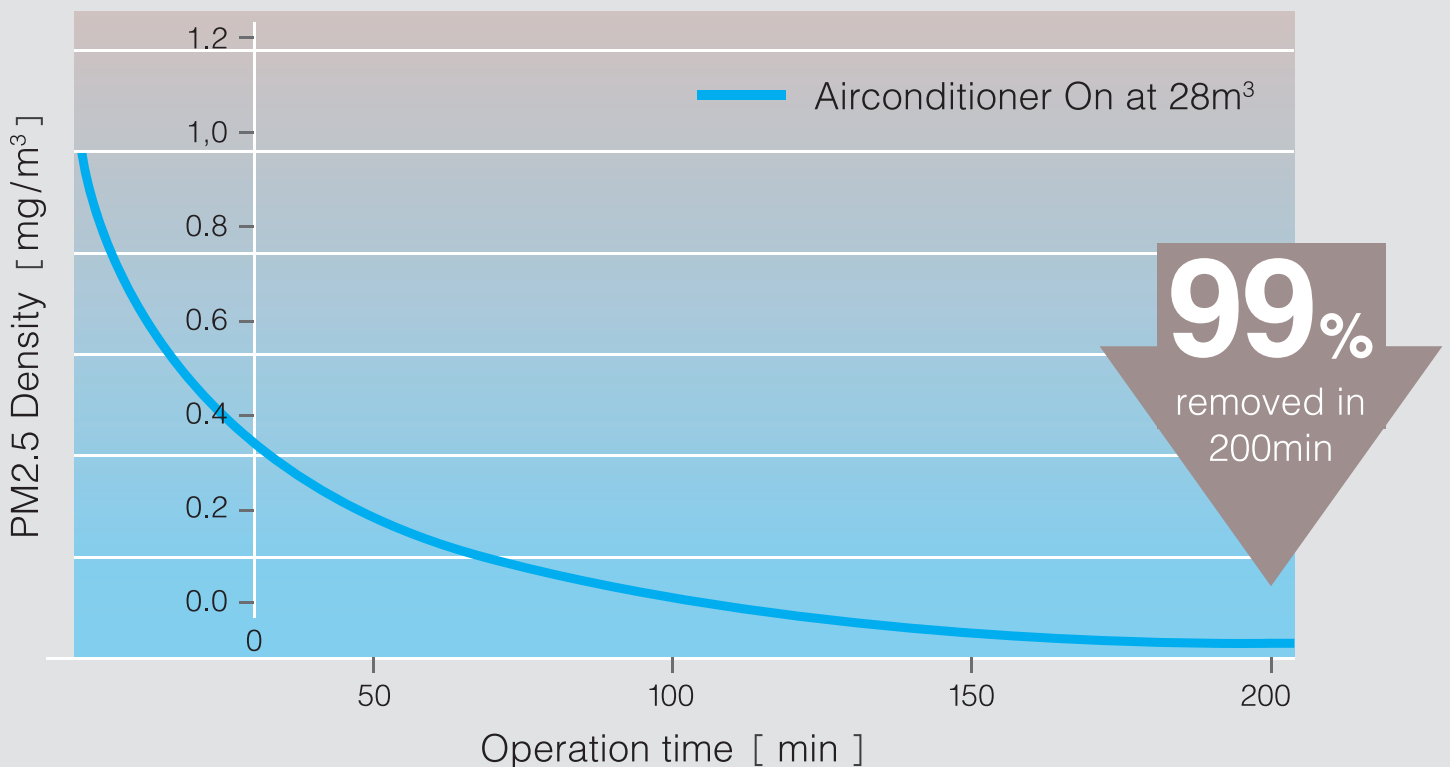

Test conditions:

Removal efficiency of particulates sizes ranging 0.3-2.5µm after operation for 200min using MSY-JP22VF microparticle catching filter in 28m<sup>3</sup> enclosed space with tidal air circulation volume of 0.5/hr (in-house test)

Effectively catches floating PM2.5 particles to maintain clean air in the room.

Electrostatic material removes PM2.5 from the air and absorbs it when passing through the filter

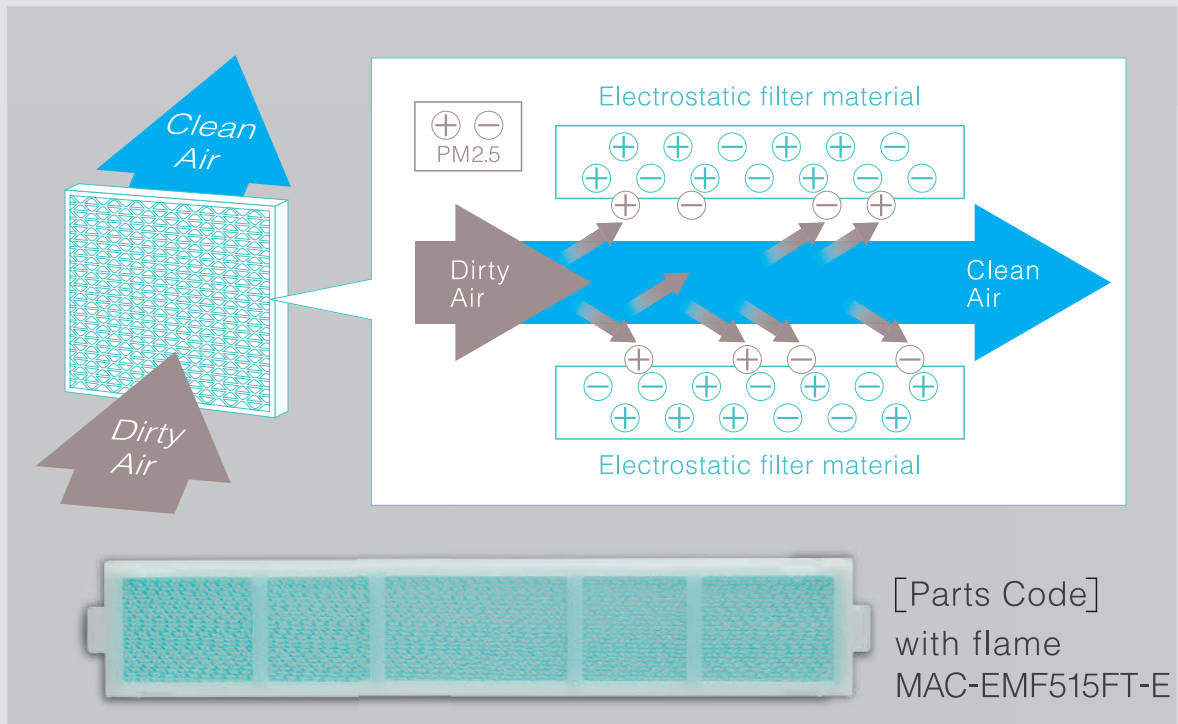

## Comparison of **Global-Warming Potential**

New R32 refrigerant has a global warming potential approximately 1/3 that of our current refrigerant, R410A; thereby dramatically reducing the negative impact more than ever. Actively introducing the new R32 refrigerant to suppress global warming, MITSUBISHI ELECTRIC continues to promote manufacturing while considering the environment.

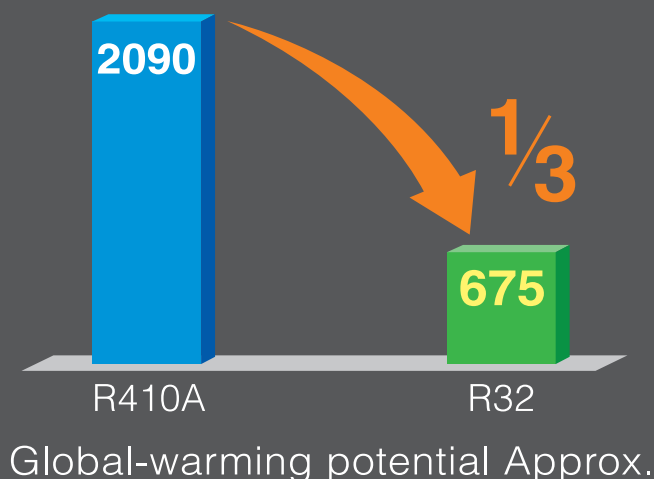

# POWERFUL COOL

Push the Powerful Cool button when you need to cool down quickly, such as when you return home on a hot day, or when you have guests over.

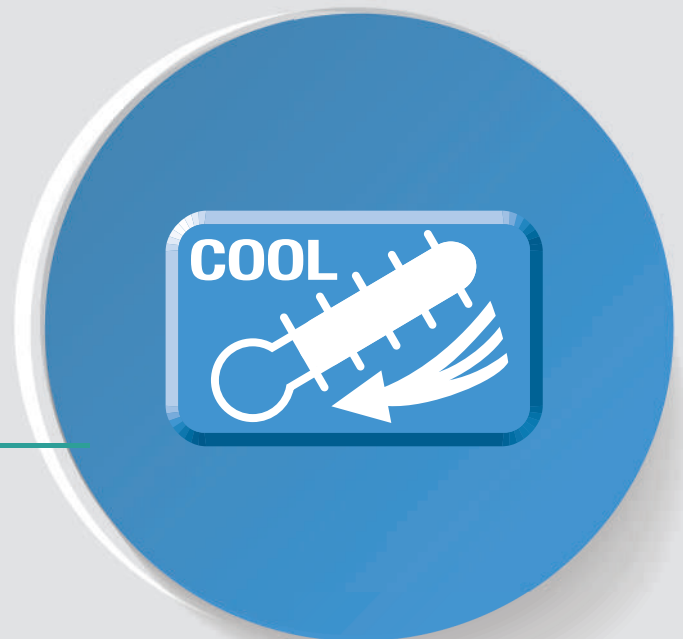

Once activated, this mode continues for 15 minutes.

## Powerful Cool

Cooling starts immediately with the push of a button



12-Hour On/Off timer



Battery Replacement Indicator





# YJP Series SPECIFICATIONS

Type	Cooling only						
Model name	Indoor unit		MSY-JP10VF	MSY-JP13VF	MSY-JP15VF	MSY-JP18VF	MSY-JP22VF
	Outdoor unit		MUY-JP10VF	MUY-JP13VF	MUY-JP15VF	MUY-JP18VF	MUY-JP22VF
Refrigerant	R32						
Power supply	Source	Single phase, 230V, 50Hz					
		Outdoor power supply					
Capacity	Rated (Min-Max)	kW	2.6 (0.6-2.7)	3.6 (0.9-3.7)	4.2(1.2-4.2)	5.2 (1.3-5.3)	6.0 (1.4-6.2)
Total Input	Rated (Min-Max)	kW	0.95 (0.22-1.00)	1.29(0.30-1.35)	1.44(0.35-1.59)	1.86(0.31-2.02)	1.95 (0.32-2.20)
ISEER			3.76	3.72	3.73	3.70	3.72
SPL	Indoor unit (Quiet-Lo-Med-Hi-SHi)	dB(A)	21-25-31-37-43	22-28-34-40-43	26-31-37-42-46	28-33-40-44-49	29-37-41-45-51
Air Volume	Indoor unit (Quiet-Lo-Med-Hi-SHi)	CFM	140-215-280-345-434	190-247-331-397-452	228-278-352-419-475	233-317-417-483-538	253-334-417-536-671
Operating Current	Rated	A	4.6	6	6.8	8.5	8.7
	Max	A	6.7	7.1	8.4	9.6	10.3
Indoor unit	Dimensions (H x W x D)	mm	280x838x228	280x838x228	280x838x228	280x838x228	305 x 923 x 250
	Weight	kg	8	8.5	8.5	9	12.5
Outdoor unit	Dimensions (H x W x D)	mm	454x660x235	538x698x249	538x698x249	550x800x285	550x800x285
	Weight	kg	18	22.5	24.5	31.5	31.5
Ext.Piping	Diameter Liquid	mm (inches)	6.35(1/4)	6.35(1/4)	6.35(1/4)	6.35(1/4)	6.35(1/4)
	Diameter Gas	mm (inches)	9.52(3/8)	9.52(3/8)	9.52(3/8)	12.7(1/2)	12.7(1/2)
	Max.Length Out-In	m	20	20	20	20	30
	Max.Height Out-In	m	12	12	12	12	12
Star Rating			3star	3star	3star	3star	3star

Pre filter	ANTI-MOLD						
Air cleaning filter	ELECTROSTATIC ANTI-ALLERGY ENZYME FILTER (Option), MICROPARTICLE CATCHING FILTER (Option)						
Timer			12h	12h	12h	12h	
"Control wiring (Copper)"	ODU to IDU	Core No. x Sq.mm	4C x 1.0	4C x 1.0	4C x 1.0	4C x 1.0	4C x 1.0
"Power cable (Copper)"	To ODU	Core No. x Sq.mm	3C x 1.0	3C x 1.0	3C x 1.0	3C x 1.0	3C x 2.0
"ODU Breaker Size"	To ODU	A	10	10	10	10	16

## FUNCTIONS & FEATURES

- |  |   |  |
|--|---|--|
|  Joint Lap DC Motor          |  Grooved Piping                                  |  Horizontal vane swing                                     |
|  Auto Restart                |  Vector Wave Eco Inverter                        |  Magnetic Flux Vector Sine Wave Drive                      |
|  Anti-Mold filter            |  Auto Fan Speed Mode                             |  Blue Fin for Outdoor condenser (Corrosion toughness)      |
|  PAM (Basic)                 |  Reluctant DC Rotary Compressor                  |  Electrostatic Anti-allergy Enzyme Filter (Optional parts) |
|  Long Airflow *MSY-JP22VF    |  Single Coating                                  |  Electronic Metal Housing Box                              |
|  Econo Cool                  |  Micro Particle Catching Filter (Optional parts) |  Dual Barrier Coating                                      |
|  Heat Caulking Fixing Method |   |  |

# YJP Series



MSY-JP22VF

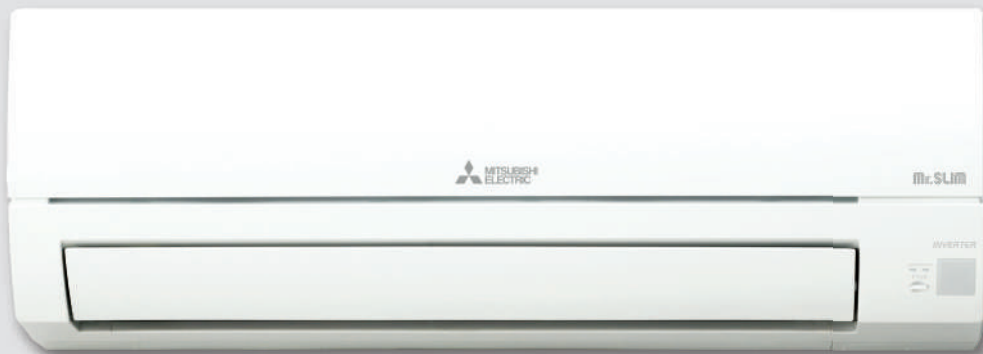

MSY-JP10/13/15/18VF

 **MITSUBISHI  
ELECTRIC**  
AIR CONDITIONERS



# GK Series

(Non-Inverter Cooling Only)

## Mr. SLIM

Range of Split Air Conditioner



---

Comfortable **ME**

---



\*MS-GK10/13 VA



Mitsubishi Electric's unwavering commitment to research and development is helping us create the next generation of groundbreaking technologies. Through our research centers around the world, we're taking on the challenges of technology to contribute to a better society in the future.

	Composition	Ozone depletion potential factor*	Toxicity	Stability
NEW REFRIGERANT	Non-uniform boiling point composite refrigerant			
<b>R410A</b>	<b>(HFC:R32/R125=50:50WT%)</b>	<b>0</b>	<b>NON</b>	<b>GOOD</b>
CURRENT REFRIGERANT	Single component refrigerant			
<b>R22</b>	<b>(HCFC:R22=100WT%)</b>	<b>0.05</b>	<b>NON</b>	<b>GOOD</b>

\* Relative value when CFC is considered as 1

Many scientist believe that refrigerants that contain hydrochlorofluorocarbons such as HCFC-R22 with chlorine are a contributing factor to this problem. R410A - a chlorine-free, non-inflammable, environmentally friendly and energy efficient refrigerant offers a new alternative, in addition to the properties just mentioned, R410A is a easy to handle as the environmentally unfriendly R22 because of its pseudoazeotropic characteristics.

R410A is also highly efficient and provides the same level of performance as R22

### Nano Platinum Filter

The filter has a large capture area and incorporates nanometre-sized platinum - ceramic particales that work to kill bacteria and deodourise the circulating air. Better dust collection than conventional filters is also ensured.

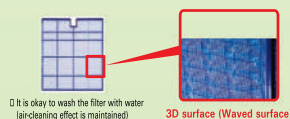

\*Available in MS-GK Series



### Econo Cool - smart save

The Econo Cool one touch operation automatically adjusts the direction of airflow based on the temperature at the air outlet. The set temperature can therefore be 2°C above conventional temperature settings without loss of comfort and with a 20% increase in energy efficiency.

**Ensures greater comfort even when the temperature setting is 2 °C above conventional settings.**

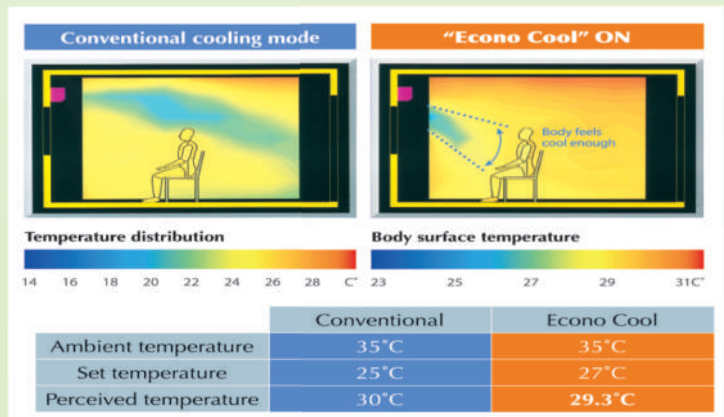

### Electrostatic Anti- Allergy Enzyme Filter

The filter is charged with static electricity, enable it to trap allergens such as molds and bacteria and decompose them using enzymes retained in the filter.

\*Optional



## Wide & Long Airflow

Bringing extra comfort to your life, left-right vane can be automatically controlled by remote controller. Simply use of Wide vane mode, you can easily adjust direction of airflow to reach any corner of the room. The high-power motor combines with a newly designed "long mode" to push air out further, providing an extended airflow that can reach the far end of long living rooms or each the kitchen in open-concept living areas and studios. When operating in Long mode, the airflow can be extended as far as 12m.

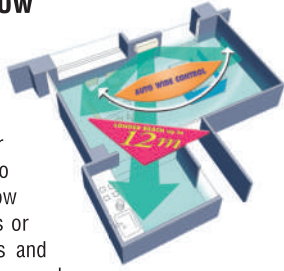

### Improved efficiency with 7-way airflow

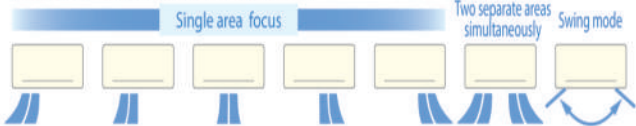

By combining the use of Wide-vane mode and Long and vane mode, you can adjust airflow horizontal 7 directions and vertical 6 directions. Exclusive to Mitsubishi Electric, this advantage ensures maximum control over air direction and flow up to 42 ways, which guarantee that the air conditioning effect isn't wasted, where it isn't needed.



## LCD Remote Control

From temperature and operation mode to air volume and direction, you'll be able to customize your environment at a touch of a button. Large, easy-to-identify buttons allow for easy access to frequently used functions. The generous LCD display lets you check temperature and other operating conditions at a glance, while an easy open slide cover prevents inadvertent operation of preset controls and other functions.

**Auto Mode:** We offer you an easy way to comfort with auto mode. "Auto Vane" is created to set the vane angle automatically. These could let ideal temperature to be achieved in the shortest amount of time.

**Mode Change :** Change to "I FEEL" - "COOL" - "FAN" - "DRY"

**Area Settings :** Efficient cooling is realized for the target space.



## Fuzzy Logic "I Feel"

In the room too hot or cold, too dry or humid? On auto mode selection, the fuzzy logic control system adjusts conditions to suit you. Your selected temperature setting is stored in the memory system and reproduced automatically each time you operate your air conditioning.



## Electronic Metal Housing Box

This special box protects the electronic circuitry from dust ensuring its reliable operation and preventing fire in the event of a short circuit.



## Grooved Piping

High-performance grooved piping is used in heat exchangers to increase the heat exchange area

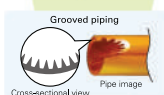

## Anti-rust

All outdoor cabinets have been treated with special anti-rust painting.

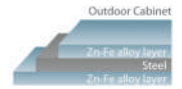

## Powerful Cool

The automatic, one-touch Powerful Cool system ensures faster cooling. It produces 10% more airflow than the "high fan" speed, cooling the room in less than 15 minutes, then automatically returning to the regular setting.



## Computerized dehumidification

Eliminate dampness without lowering the temperature for healthier, more comfortable air-conditioning, while enjoying great year-round economy.



## 24 Hour Timer

On/Off operation can be set simultaneously in 10-minute increment for a 24-hour period.



## 12 Hour On and Off Timer



## Auto Restart

This function permits automatic return to previous operation conditions after a sudden power black-out. You can now sleep peacefully all through the night without having to get up and turn your air-conditioner back on.



## Self-diagnostic function

In the unlikely event of a malfunction, the LED on the indoor unit flashes to indicate the exact spot to be checked.



## Auto Vertical Vane

The air outlet vane swings left and right so that the airflow is spread quickly in the room.

\* Available in MS-GK18/24



## Auto Horizontal Vane

The air outlet vane swings up and down so that the airflow is spread evenly throughout the room



## DC Fan Motor

A highly efficient DC motor drives the fan of the indoor unit. Efficiency is much higher than an equivalent AC motor.

# MS-GK Series



MS-GK10/13/VA



LCD Remote Controller



MS-GK18/24/VA



LCD Remote Controller



MU-GK10/13 VA







MU-GK24 VA



MU-GK18 VA

## Specifications - GK Series

Indoor Unit				MS-GK10VA	MS-GK13VA	MS-GK18VA	MS-GK24VA
Outdoor Unit				MU-GK10VA	MU-GK13VA	MU-GK18VA	MU-GK24VA
Power Supply	Source	Outdoor Power supply					
	Outdoor(V/Phase/Hz)	230V/SinglePhase/50Hz					
Function				Cooling Only			
Capacity	Rated	kW	2.7	3.6	5.2	6.6	
	TR	TR	0.75	1.0	1.5	2.0	
Total Input	Rated	kW	0.740	1.000	1.450	1.850	
EER			3.65	3.60	3.59	3.57	
Sound Level (SPL)	Indoor Unit (Lo/Mid/Hi/Shi)	dB(A)	26/32/38/44	29/36/42/46	35/41/47/53	37/42/47/53	
Air Volume	Indoor Unit	CFM	448	477	777	777	
Operating Current			A	3.3	4.5	6.4	8.2
Indoor Unit	Dimensions	H*W*D	mm	290 x 799 x 232		325 x 1100 x 238	
	Weight		kg	9	10	16	
Outdoor Unit	Dimensions	H*W*D	mm	525 x 718 x 255		550x800x285	880 x 840 x 330
	Weight		kg	24.5	33.5	40	63
	Breaker Size (MCB required)		A	10	10	15	20
Ext. Piping	Diameter	Liquid/Gas	mm	6.35 / 9.52	6.35 / 12.7	6.35 / 15.88	6.35 / 15.88
	Max.Length	Out-In	m	20	20	30	30
	Max.Height	Out-In	m	10	10	10	10
Refrigerant				R410A	R410A	R410A	R410A
BEE Star Rating							

**GS**  
Series

Fixed Speed

**BLOWS FAST  
COOLS SUPERFAST**



# Operating Range upto 50°C

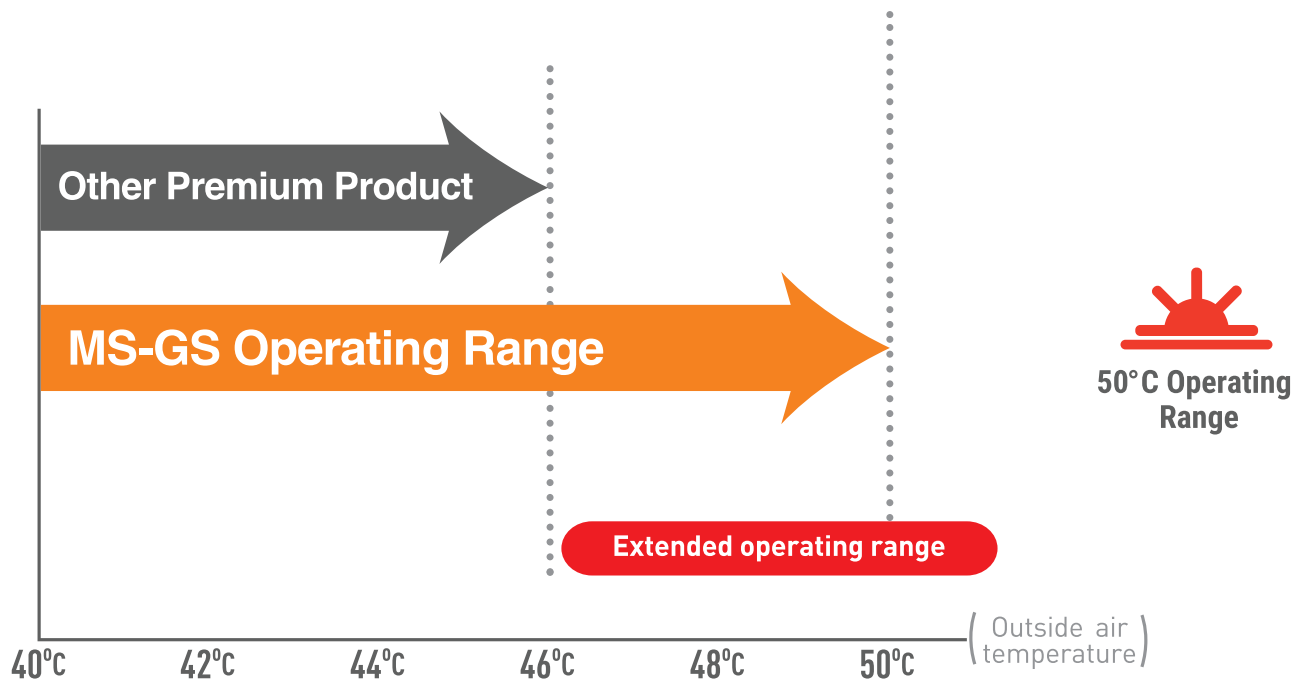

## Tropical Technology

Mitsubishi Electric introduces the new Tropical series. Use of latest & innovative technologies in compressor has made it possible for Air conditioners to operate at outside air temperatures as high as 50°C.

This series has been specially designed keeping in mind, homes in the tropical regions.



Best-in-class Comfort



Powerful Cooling



Instant Relief from tropical heat



# High CFM

## 777\*

### CMH-1320



High Airflow Rate



Immediate Relief from Scorching heat



Edge over Competition in similar category

### Powerful Cool

Push the Powerful Cool button when you need quick and effective cooling, such as when you return home on a hot day, or when you have guests over.

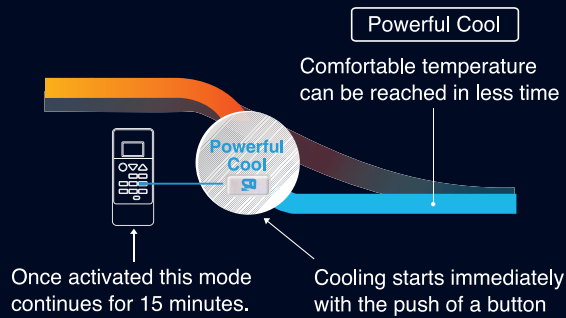

\*Available in MS-GS18

# Comparison of Global Warming Potential

New R32 refrigerant has a global warming potential which is approximately 1/3rd that of R410A, thereby dramatically reducing the negative impact more than ever.

By actively introducing the new R32 refrigerant to suppress global warming, MITSUBISHI ELECTRIC continues to promote manufacturing while considering the environment.



Global warming potential approx.

## Econo Cool Smart Save

The Econo Cool one-touch operation automatically adjusts the direction of airflow based on the temperature at the air outlet.

The set temperature can therefore be 2°C above conventional temperature settings without any loss of comfort and as a 20% increase in energy efficiency.

Ensuring greater comfort even when the temperature setting is up to 2°C higher as compared to conventional settings.

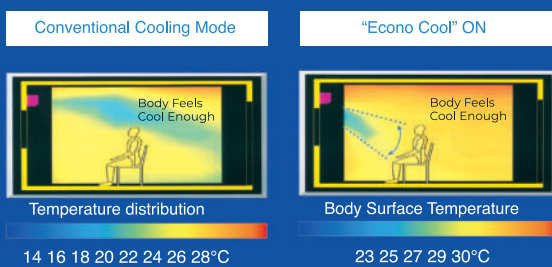

	Conventional	Econo Cool
Ambient Temperature	35°C	35°C
Set Temperature	25°C	27°C
Perceived Temperature	30°C	29.3°C

# Anti-Corrosion Coating for Indoor Units

Extreme weather conditions, presence of sulphur content in air and several other foreign substances may sometime cause **leakage of gas** from AC coil bends of indoor units.

**Mitsubishi Electric** provides an **Anti-Corrosion Coating** on AC coil bends, preventing leakage of Refrigerant from the Air conditioner.

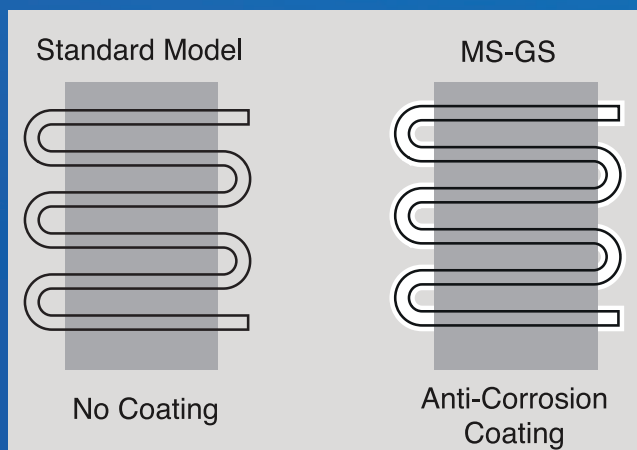

## Anti-Corrosion Coating for Indoor Units



Before Coating



After Coating

# Micro Particle Catching Filter<sup>1</sup> (PM 2.5)

Introduced for the first time in fixed speed AC.

The filter effectively catches floating PM 2.5 particles to maintain clean air in the room.

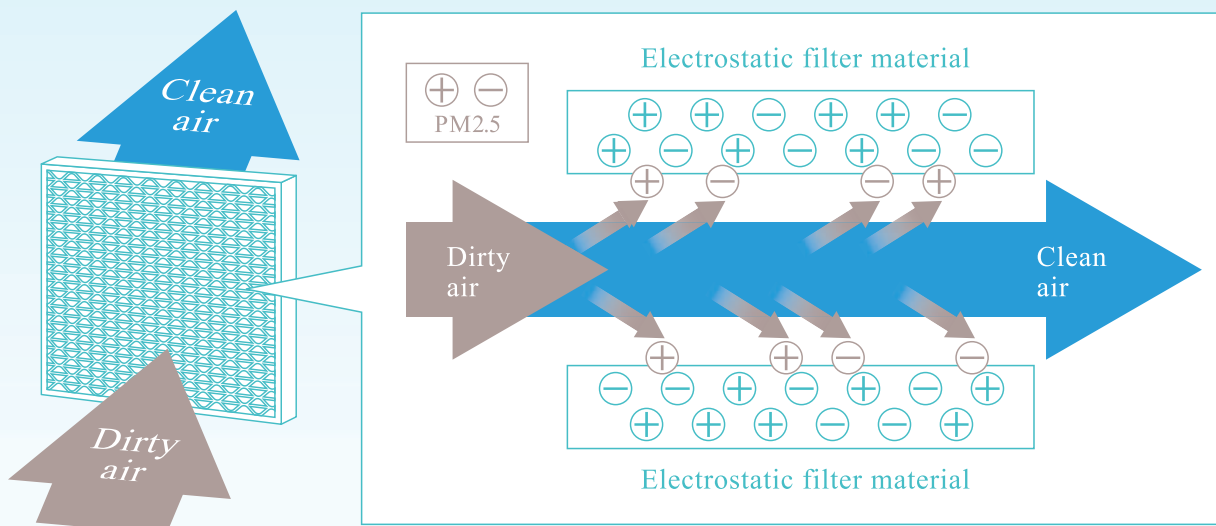

Electrostatic material removes PM 2.5 from the air and absorbs it when passing through the filter



MAC-EMF515FT-E &  
MAC-EMF615FT-E  
(Optional parts)

<sup>1</sup> Optional

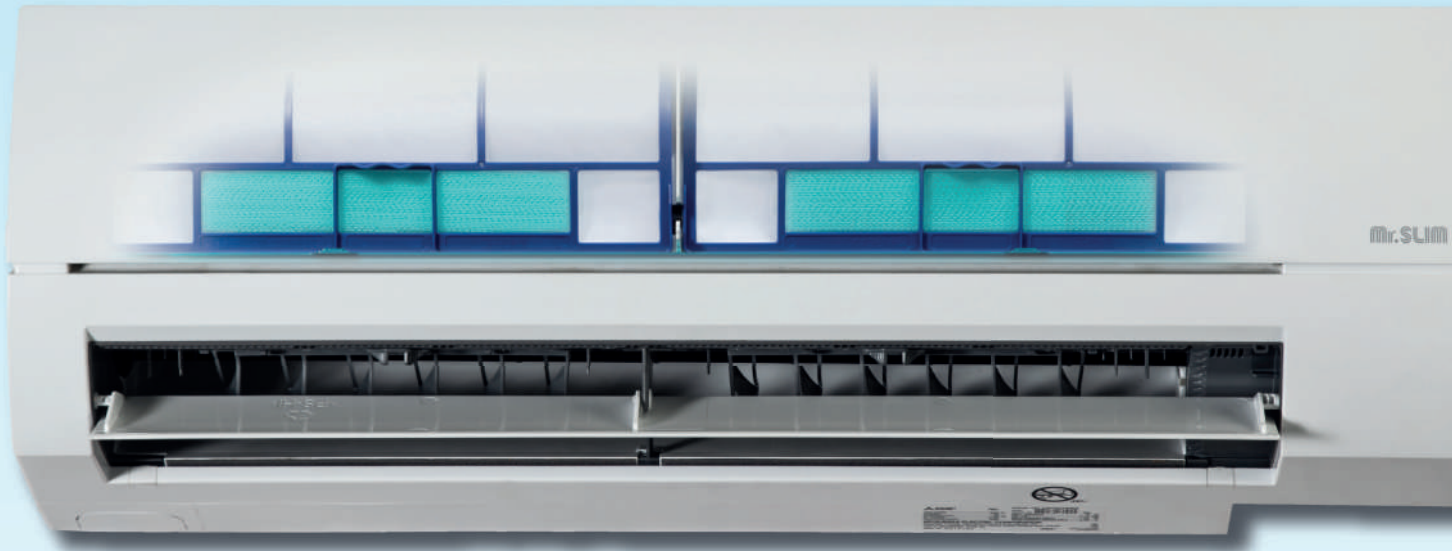

## PM2.5 Removal Efficiency

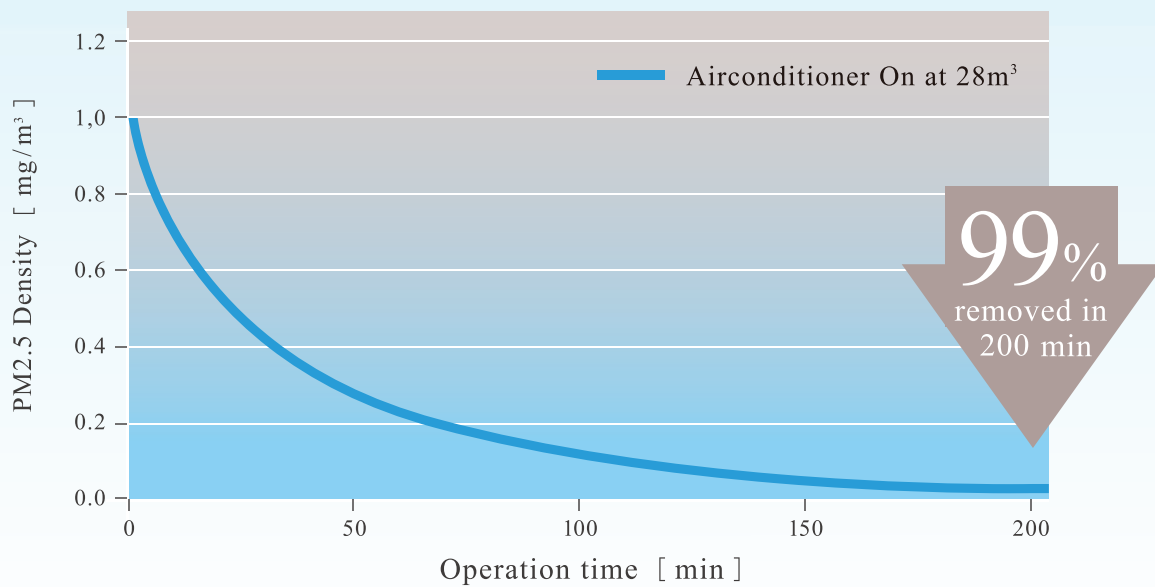

**Test conditions:** Removal efficiency of particulates sizes ranging 0.3-2.5 $\mu$ m after operation for 200 min using MS-GS microparticle catching filter in 28m<sup>3</sup> enclosed space with tidal air circulation volume of 0.5/hr (in-house test)

# Features & Functions



## Anti Rust

All outdoor cabinets have been treated with special anti-rust painting.



## Grooved Piping

High performance grooved piping is used in heat exchangers to increase the heat exchange area.



## Computerized Dehumidification

Eliminates dampness without lowering the temperature for healthier, more comfortable air conditioning, while enjoying great year-round economy.



## Electrostatic Anti-allergy Enzyme Filter (Optional)

The filter is charged with static electricity, enables it to trap allergens such as molds and bacteria and decompose them using enzymes retained in the filter



## 24 Degree Default Setting



## Electronic Metal Housing Box

This special box protects the electronic circuitry from dust ensuring its reliable operation and preventing fire in the event of a short circuit.



## Powerful Cool

The automatic, one-touch cool system ensures faster cooling. it produces 10% more airflow than the "high fan" speed, cooling the room in less than 15 minutes, then automatically returns to the regular setting.



## Fuzzy Logic "I Feel"

Is the room hot or cold, too dry or humid? On auto mode selection, the fuzzy logic control adjusts conditions to suit you. Your selected temperature setting is stored in the memory system and reproduced automatically each time you operate your air conditioning.



## 100% Copper Heat Exchanger



## Auto Restart

The function permits automatic return to previous operation after a sudden power blackout.



## Auto Horizontal Vane

The air outlet vane swings up and down so that the airflow is spread evenly throughout the room.



## Anti Mold

Nano platinum air purifying filter suppresses fungal growth to keep the air fresh and free of mold at all the time.



## Cleaning Free Pipe Reuse

The technology allows to reuse existing R22 refrigeration piping even when installing a new R32 model.



## 12 Hour On and Off timer

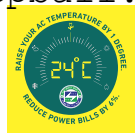

# Specifications

Type	Cooling only					
Model name	Indoor unit		MS-GS10VF	MS-GS13VF	MS-GS18VF	MS-GS24VF
Model name	Outdoor unit		MU-GS10VF	MU-GS13VF	MU-GS18VF	MU -GS24VF
Refrigerant	R32					
Power supply	Source	Single phase, 230V, 50Hz				
		Outdoor Power Supply				
Capacity	Rated	Kw	2.65	3.60	5.20	6.60
	TR	TR	0.80	1.00	1.50	1.90
Total input	Rated	Kw	0.75	1.02	1.47	1.87
ISEER			3.53	3.53	3.54	3.53
SPL	Indoor unit (Lo-Med-Hi-SHi)	dB(A)	26-33-40-47	29-37-42-47	34-39-44-51	35-41-46-51
Air Volume	Indoor unit (Lo-Med-Hi-SHi)	CFM	162-212-311-424	251-270-340-408	427-507-585-777	427-490-585-791
Operating Current	Rated	A	3.4	4.6	6.9	8.6
Indoor unit	Dimensions (H x W x D)	mm	290x 799x 232	290x 799x 232	325x 1100x 238	325x 1100x 238
	Weight	kg	9.0	9.5	16.0	15.0
Outdoor unit	Dimensions (H x W x D)	mm	525x 718x 255	525x 718x 255	525x 718x 255	880x 840x 330
	Weight	kg	24.5	34.0	34.0	55.5
Ext. Piping	Diameter Liquid	mm (inches)	6.35 (1/4)	6.35 (1/4)	6.35 (1/4)	6.35 (1/4)
	Diameter Gas	mm (inches)	9.52(3/8)	9.52(3/8)	12.7(1/2)	15.8(5/8)
	Max.Length Out-In	m	20	20	30	30
	Max.Height Out-In	m	10	10	10	10
Star Rating			3	3	3	3

Pre Filter	Anti Mold					
Air cleaning filter	ELECTROSTATIC ANTI-ALLERGY ENZYME FILTER (Option)					
Timer			12h	12h	12h	12h
Control Wiring (Copper)	ODU to IDU	Core No. x Sq. mm	4C X 1.0	4C X 1.0	4C X 1.0	4C X 1.0
Power Cable (Copper)	To ODU	Core No. x Sq. mm	3C X 1.0	3C X 1.0	3C X 2.5	3C X 2.5
ODU Breaker	To ODU	A	10	10	15	20
Outdoor Guaranteed Operating range (Min-Max)		°C	46	50	50	50

- Rating conditions Cooling - Indoor: 27°C (80°F) DB, 19°F (66°F) WB, Outdoor. 35°C (95°F)
- Refrigerant piping length (one-way): 5.0m (16.4ft)
- Total input based on the indicated voltage (indoor/outdoor): 1 phase 230V 50Hz.



AIR CONDITIONERS

Mr.SLIM

New Range of Split Air Conditioner



JP  
Series

(Non-Inverter Cooling Only)



Guaranteed Operating Range  
Up to **50°C**



# Guaranteed Operating Range Up to 50°C

## Tropical Technology

Mitsubishi Electric introduces the new Tropical Specification series. New technologies used in the compressor has made it possible for units to operate at outside air temperatures as high as 50°C. The new Tropical Specification series is perfect for cooling homes in tropical regions.

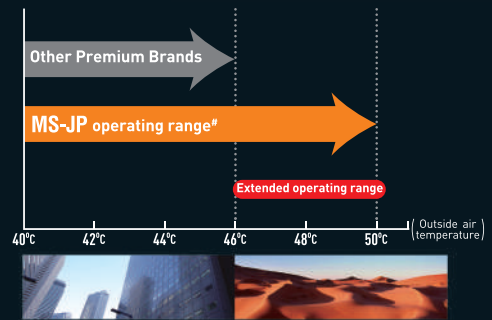

\*Available in MS-JP 13/18/24BF



## NANO Platinum Filter

The filter has a large capture area and incorporates nanometre-sized platinum – ceramic particles that work to kill bacteria and deodorise the circulating air. Better dust collection than conventional filters is also ensured.

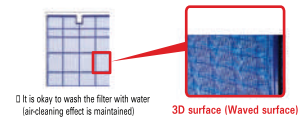

## Econo Cool – Smart Save

The Econo Cool one touch operation automatically adjusts the direction of airflow based on the temperature at the air outlet. The set temperature can therefore be 2°C above conventional temperature settings without loss of comfort and with a 20% increase in energy efficiency.

Ensures greater comfort even when the temperature setting is 2°C above conventional settings.

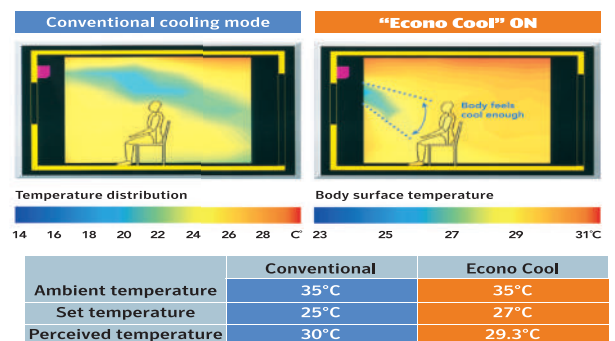

# Comparison of Global Warming Potential

New R32 refrigerant has a global warming potential approximately 1/3 that of our current refrigerant. R410 A: thereby dramatically reducing the negative impact more than ever, actively introducing the new R32 refrigerant to suppress global warming. MITSUBISHI ELECTRIC continues to promote manufacturing while considering the environment.

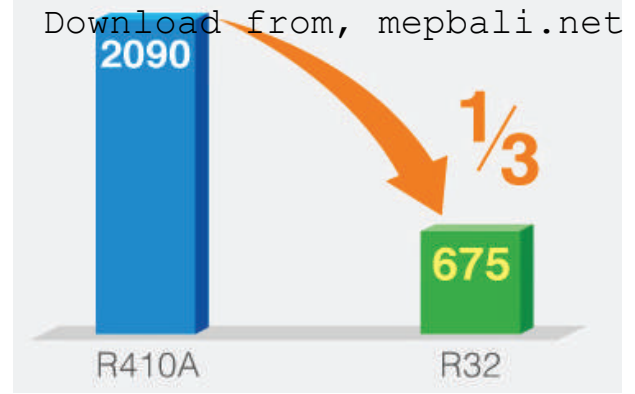

Global warming potential approx.

## IDU Anti-corrosion Coating



Before Coating

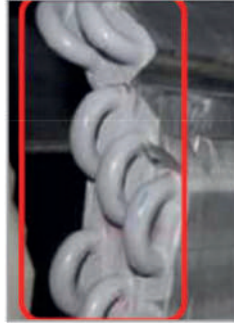

After Coating

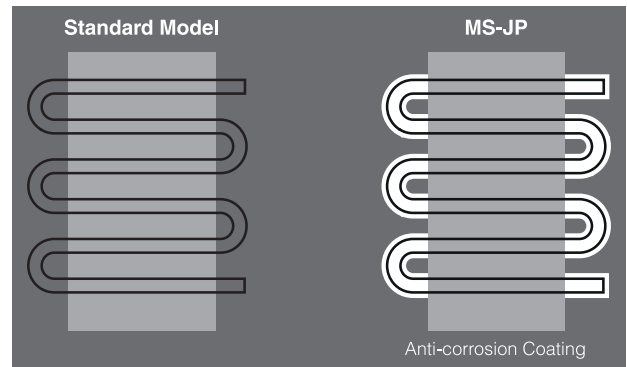

'Anti-corrosion Coating' is done to prevent gas leakage from AC coil bend which is very frequent in Indian market conditions



### Anti Rust

All outdoor cabinets have been treated with special anti-rust painting.



### Grooved Piping

High-performance grooved piping is used in heat exchangers to increase the heat exchange area.



### Computerized Dehumidification

Eliminate dampness without lowering the temperature for healthier, more comfortable air conditioning, while enjoying great year-round economy.



### 100% Copper Heat Exchanger



### LCD Remote Control



### Electrostatic Anti-allergy Enzyme Filter

The filter is charged with static electricity, enables it to trap allergens such as molds and bacteria and decompose them using enzymes retained in the filter.

\*Optional



### Fuzzy Logic "I Feel"

Is the room too hot or cold, too dry or humid? On auto mode selection, the fuzzy logic control system adjusts conditions to suit you. Your selected temperature setting is stored in the memory system and reproduced automatically each time you operate your air conditioning.



### Electronic Metal Housing Box

This special box protects the electronic circuitry from dust ensuring its reliable operation and preventing fire in the event of a short circuit.



### 24 Hour Timer

On/Off operation can be set simultaneously in 10 minute increment for a 24 hour period.



### Powerful Cool

The automatic, one-touch powerful cool system ensures faster cooling. It produces 10% more airflow than the "high fan" speed, cooling the room in less than 15 minutes, then automatically returning to the regular setting.



### 12 Hour On and Off Timer



### Auto Restart

This function permits automatic return to previous operation conditions after a sudden power blackout.



### Self-diagnostic Function

In the unlikely event of a malfunction, the LED on the indoor unit flashes to indicate the exact spot to be checked.



### Auto Horizontal Vane

The air outlet vane swings up and down so that the airflow is spread evenly throughout the room.



### Anti Mold



Nano platinum air purifying filter suppresses fungal growth to keep the air fresh and free of mold at all time.



### DC Fan Motor

A highly efficient DC motor drives the fan of the indoor unit. Efficiency is much higher than an equivalent AC motor.

# Specification Table

Type	Cooling only			
Model name	Indoor unit		MS-JP10VF	MS-JP13VF
	Outdoor unit		MU-JP10VF	MU-JP13VF
Refrigerant	R32			
Power supply	Source	Single phase, 230V, 50Hz		
		Outdoor power supply		
Capacity	Rated	kW	2.65	3.60
	Max	kW	2.65	3.60
Total Input	Rated	kW	0.77	1.06
ISEER			3.44	3.40
SPL	Indoor unit (Lo-Med-Hi-SHi)	dB(A)	26-33-40-47	29-37-42-47
Air Volume	Indoor unit (Lo-Med-Hi-SHi)	CFM	162-212-311-422	217-270-340-408
Operating Current	Rated	A	3.4	4.7
Indoor unit	Dimensions (H x W x D)	mm	290x799x232	
	Weight	kg	9	
Outdoor unit	Dimensions (H x W x D)	mm	525x718x255	
	Weight	kg	24.5	31.5
Ext.Piping	Breaker Size (MCB required)	A	10	10
	Diameter Liquid	mm (inches)	6.35(1/4)	6.35(1/4)
	Diameter Gas	mm (inches)	9.52(3/8)	9.52(3/8)
	Max.Length Out-In	m	20	20
	Max.Height Out-In	m	10	10
Star Rating				

Pre filter	ANTI-MOLD			
Air cleaning filter			ELECTROSTATIC ANTI-ALLERGY ENZYME FILTER (Option)	
Timer			12h	12h
Control wiring (Copper)	ODU to IDU	Core No.xSq.mm	4C x 1.0	4C x 1.0
Power cable (Copper)	To ODU	Core No.xSq.mm	3C x 1.0	3C x 1.0
ODU Breaker Size	To ODU	A	10	10

## MS-JP SERIES



**MS-JP18/24VF**



**MU-JP24VF**





**MU-JP10/13/18VF**



**MS-JP10/13VF**

# Specification Table

Type	Cooling only			
Model name	Indoor unit		MS-JP18VF	MS-JP24VF
	Outdoor unit		MU-JP18VF	MU-JP24VF
Refrigerant	R32			
Power supply	Source		Single phase, 230V, 50Hz	
			Outdoor power supply	
Capacity	Rated	kW	5.35	6.60
	Max	kW	5.35	6.60
Total Input	Rated	kW	1.59	1.96
ISEER			3.36	3.37
SPL	Indoor unit (Lo-Med-Hi-SHi)		34-39-44-49	35-41-46-51
Air Volume	Indoor unit (Lo-Med-Hi-SHi)		427-507-585-699	427-490-585-764
Operating Current	Rated	A	7.1	8.9
Indoor unit	Dimensions (H x W x D)		325x1100x238	
	Weight		15	
Outdoor unit	Dimensions (H x W x D)		525x718x255	880x840x330
	Weight		32.5	50.5
Ext.Piping	Breaker Size (MCB required)		A	15
	Diameter Liquid		mm (inches)	6.35(1/4)
	Diameter Gas		mm (inches)	12.7(1/2)
	Max.Length Out-In		m	20
	Max.Height Out-In		m	10
Star Rating				

Pre filter	ANTI-MOLD			
Air cleaning filter			ELECTROSTATIC ANTI-ALLERGY ENZYME FILTER (Option)	
Timer			12h	12h
Control wiring (Copper)	ODU to IDU	Core No.xSq.mm	4C x 1.0	4C x 1.0
Power cable (Copper)	To ODU	Core No.xSq.mm	3C x 2.5	3C x 2.5
ODU Breaker Size	To ODU	A	15	20

# Mitsubishi MElectric Quality

What is MITSUBISHI ELECTRIC Quality? MEQ represents our dedication to excellence in developing and manufacturing exceptional, eco-friendly home appliances, amazing industrial products, reliable public infrastructure systems and inspiring space technologies, which are truly out of this world. And there's so much more. When you see the MEQ logo, you know something good is being created.

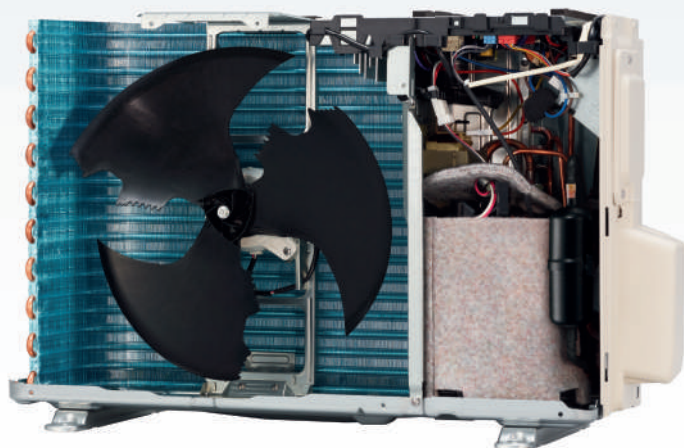

## Development

Taking into account the various harsh environments around the world, at MITSUBISHI ELECTRIC we have established uniquely strict quality control standards and various quality evaluation tests for our products.



Dropping Test

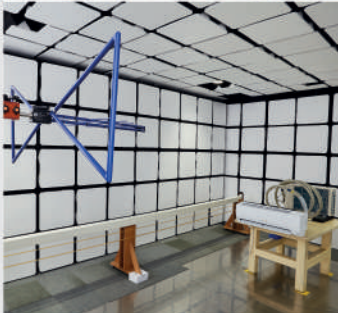

Electromagnetic Compatibility Test



Salt Spray Test



Anechoic Chamber Noise Test

## Design

In order to ensure our customers can use our products with peace of mind and for a long time, we select high-quality durable parts, and invest great care when designing

and assembling our products.

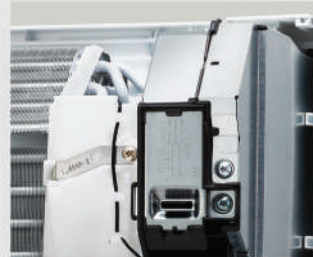

Ensure its reliable operation and preventing fire accident in case of short circuit.

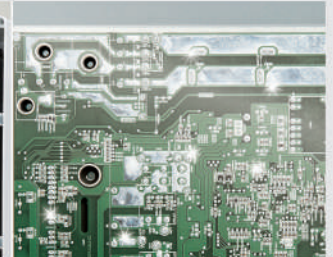

Special coating prevents any damages from humidity and insects



MITSUBISHI ELECTRIC PCB can resist high voltage up to 450V.



MITSUBISHI ELECTRIC Inverter can be smoothly operated even in 198v ~ 264V.



A special coating is applied to the heat exchanger to increase corrosion toughness.



Anti-rust painting and galvanized steel protect cabinet even under harsh environment.

## Production

MITSUBISHI ELECTRIC makes full use of advanced production technology to efficiently produce top quality products. All of our products are inspected by experienced professionals.





\*For Reference purpose only.

## MITSUBISHI ELECTRIC INDIA PVT. LTD.

**HEAD OFFICE:** 3rd Floor, Tower A, Global Gateway, MG Road, Gurugram – 122002

**Tel. No.:** (Main): 0124-6739300/ 301 Fax: 0124-4630399 **Website:** www.MitsubishiElectric.in **Email:** customersupport@asia.meap.com

### BRANCH/SALES OFFICES:

**Ahmedabad:** 079-67777888; **Bhubaneswar:** 09073949597; **Bengaluru:** 080-40201600; **Coimbatore:** 0422-4385606; **Chandigarh:** 0172-4601645; **Chennai:** 044-49232222; **Delhi:** 011-66057900; **Ghaziabad:** 011-66057900; **Hyderabad:** 040-43438888; **Indore:** 0731-4098991; **Jaipur:** 0141-4011109; **Kolkata:** 033-40858800/16-88; **Kochi:** 0484-4862093; **Lucknow:** 0522-4002607; **Ludhiana:** 0161-4061654; **Mumbai:** 022-66116200; **Nagpur:** 09921442323; **Pune:** 09922441773; **Rajkot:** 09586605009; **Surat:** 0261-4003111; **Vijaywada:** 08498894567.

### SATELLITE OFFICES:

**Agra:** 09536900140; **Amritsar:** 09780021037; **Aurangabad:** 09552572820; **Bhopal:** 08448398010; **Dehradun:** 08800878763; **Goa:** 09167113443; **Hubli:** 08448398010; **Kanpur:** 07755007767; **Patna:** 09073949596; **Raipur:** 08448397997; **Ranchi:** 0973949598; **Tirupati:** 09319591931; **Trichy:** 09205599022; **Varanasi -** 09336311110; **Vizag:** 09205987308

### TECHNICAL CENTRES:

**Ahmedabad:** 079-67777874; **Bengaluru:** 080-40201600; **Chennai:** 044-49232222; **Delhi:** 011-66057900; **Mumbai:** 022-66116200

**Customer Care Toll Free No.: 1800 102 2626**



#### E-waste Collection & Disposal process:

Customer can get complete details of company process on collection, disposal of e-waste product (i.e. 'Mitsubishi Electric' make Air Conditioner) and incentive / exchange scheme for returning of e-waste on Company website [www.mitsubishielectric.in](http://www.mitsubishielectric.in) or call on Toll free number 1800 102 2626.

