

**STRONG • EFFICIENT •
DURABLE**

HIGH PERFORMANCE PUMP



SUPASTREAM | SUPATUF MK2 | HYDROSTORM | HYDROSTORM PLUS | HYDROSTAR

WATERCO
water, the liquid of life

POOL PUMPS

The pump is the heart of your pool system as it draws the water through filtration and also recirculation to create a healthy and clean pool.

Whether you're after a pump for a new pool, or a replacement pump for an existing pool, Waterco has a great range of energy-efficient models to choose from. Incorporating the latest technology to deliver the right combination of performance and energy savings, Waterco's pumps are reliable and built to the highest standards.

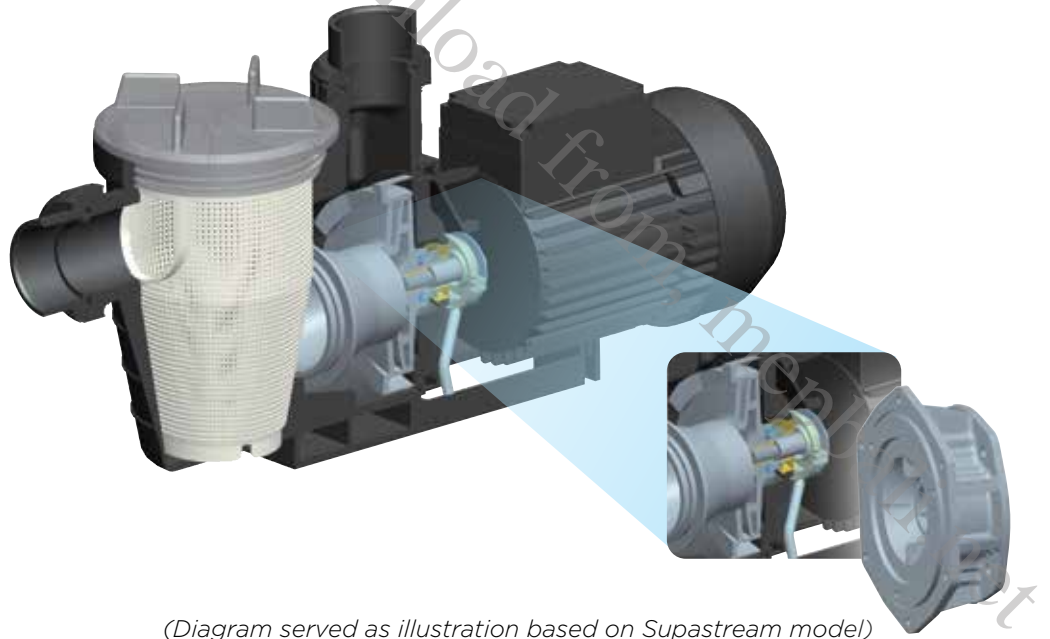

(Diagram served as illustration based on Supastream model)

FEATURES

DESIGN TO MEET EFFICIENCY

Efficient Impeller and Diffuser Design, maximizing the hydraulic output while minimizing turbulence. Thus, shortens running time & reduces energy consumption.

ENGINEERED DURABILITY

Pump body is manufactured utilising state of the art engineering plastic moulding with a single piece strainer pot and volute for extra strength.

HIGH GRADE SS316 MECH SEAL

A high-grade Carbon/ Graphite 316 stainless steel mechanical seal is incorporated for extra protection against corrosion. e.g. from chlorinated water, ozone, iodine, Baquacil, bromine and salt water.



SECONDARY PROTECTION SEAL / PUMP PROTECTION BRACKET

Designed to protect the pump motor by draining any leaks from a worn out mechanical seal.



SUPASTREAM PUMPS



Supastream pumps are general purpose pumps designed for use in swimming pools and low pressure water recirculation applications.

- Protected by secondary seal.

Pump	Inlet / outlet	Strainer basket size
Supastream 50	40mm ONLY	1.5L
Supastream 75, 100 & 150	40/50mm	1.5L

Technical Specifications

Model	Flow Rate (lpm)		Nom. HP	kW	Amps	Total Length (mm)
	6m	8m				
Supastream 50	120	60	0.50	0.563	2.55	575
Model	Flow Rate (lpm)		Nom. HP	kW	Amps	Total Length (mm)
	8m	10m				
Supastream 75	119	63	0.75	0.626	2.82	575
Supastream 100	234	169	1.00	0.793	3.50	575
Supastream 150	320	263	1.50	1.056	4.76	596

Phase	Volts	Cycle	RPM
1	220-240	50	2810

Flow Curves

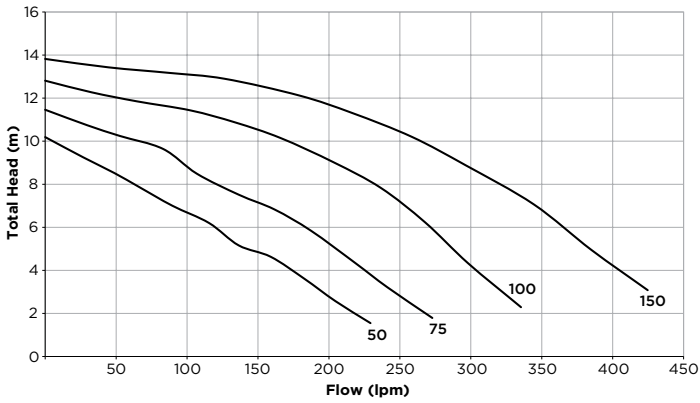

Noise Levels

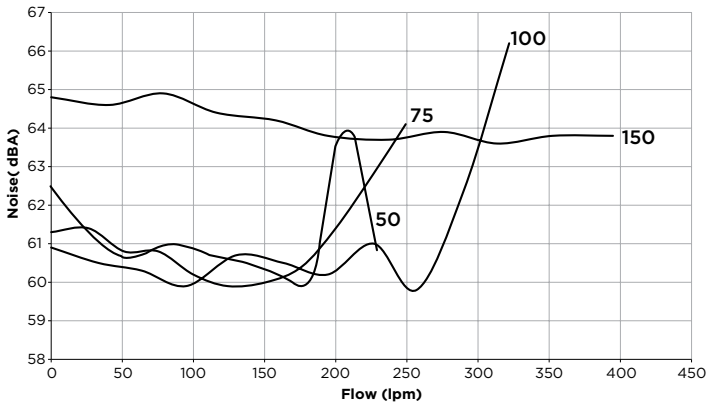

Dimension (mm)

Supastream 50

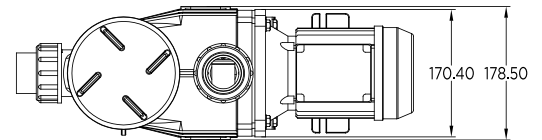
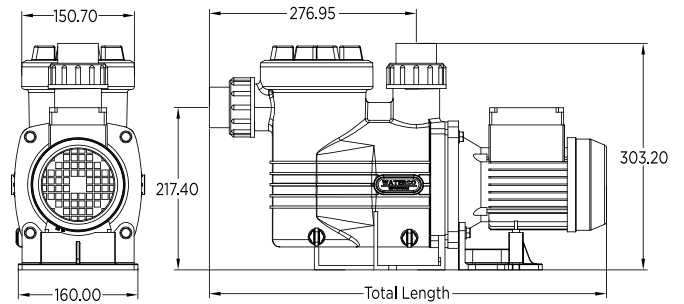

Supastream 75, 100 & 150

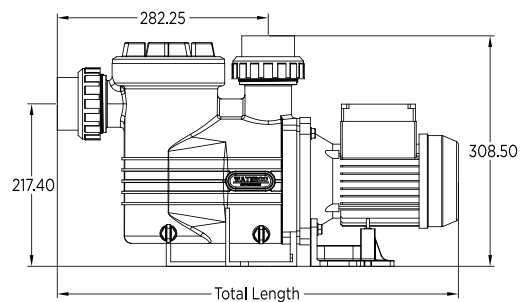

SUPATUF MK2 PUMPS



The Supatuf pump is ideal for large domestic swimming pools with ancillary systems such as heating, in-floor cleaning, fountains, vacuum cleaning and swim jets.

- Protected by secondary seal.

Pump	Inlet / Outlet	Strainer Basket Size
Supatuf MK2	50mm	2.1L

Technical Specifications

Model	Flow Rate (lpm)		kW	Nominal HP	Amp	Phase	Total Length (mm)
	8m	10m					
Supatuf 100 MK2	250	210	0.84	1.0	3.7	1	602
Supatuf 150 MK2	340	290	1.08	1.5	4.8	1	623
Supatuf 200 MK2	420	380	1.51	2.0	6.6	1	663
Supatuf 300 MK2	500	420	1.96	3.0	8.8	1	648
Supatuf 300 MK2	540	480	2.07	3.0	4.4	3	648

Phase	Volts	Cycle	RPM
1	220-240	50	2860

Phase	Volts	Cycle	RPM
3	380-415	50	2908

Flow Curves

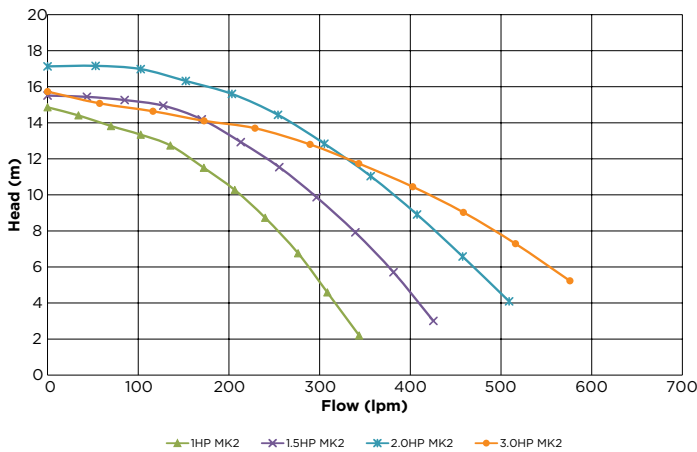

Dimension (mm)

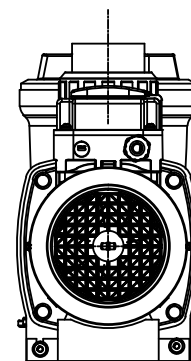
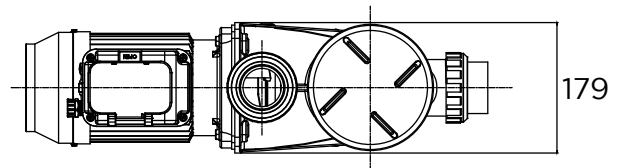
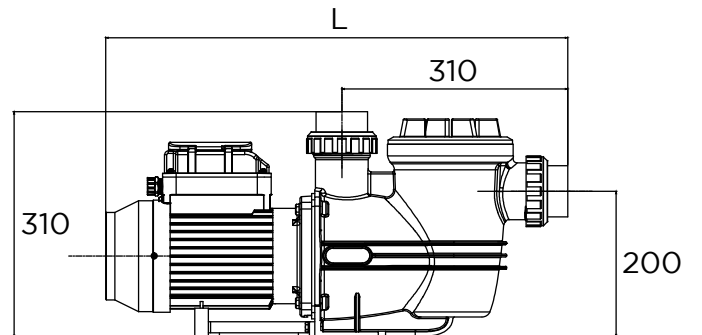

Noise Levels

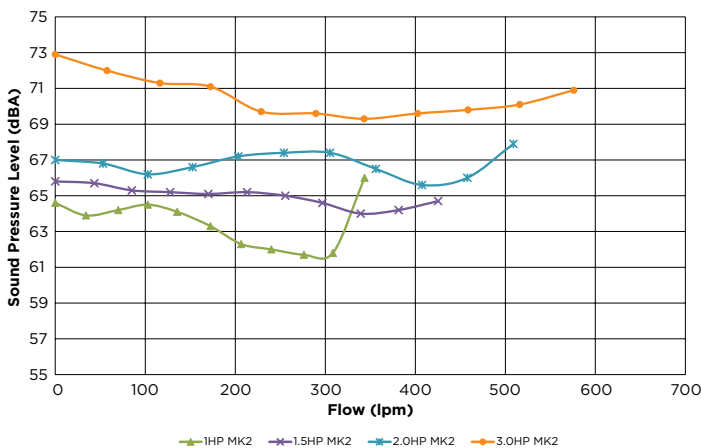

HYDROSTORM PUMPS



The Hydrostorm is designed to have all the extra power you need to cope with modern day swimming pool designs.

Pump	Inlet / Outlet	Strainer Basket Size
Hydrostorm	50mm	2.1L

Technical Specifications

Model	Flow Rate (lpm)		kW	Nominal HP	Amp	Phase	Total Length (mm)
	8m	10m					
Hydrostorm 100	250	225	0.91	1.0	4.00	1	600
Hydrostorm 150	350	315	1.31	1.5	5.80	1	647
Hydrostorm 200	370	350	1.46	2.0	6.60	1	647

Phase	Volts	Cycle	RPM
1	220-240	50	2860

Hydrostorm Flow Curves

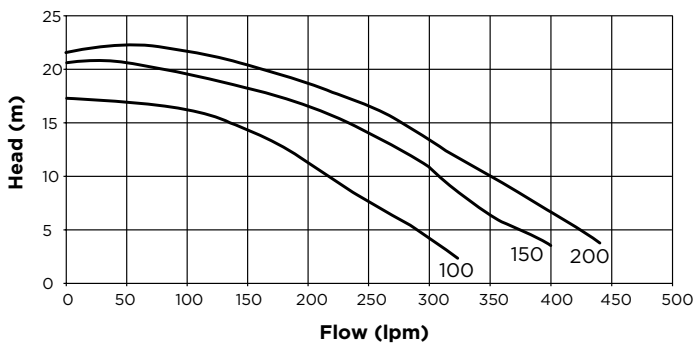

Dimension (mm)

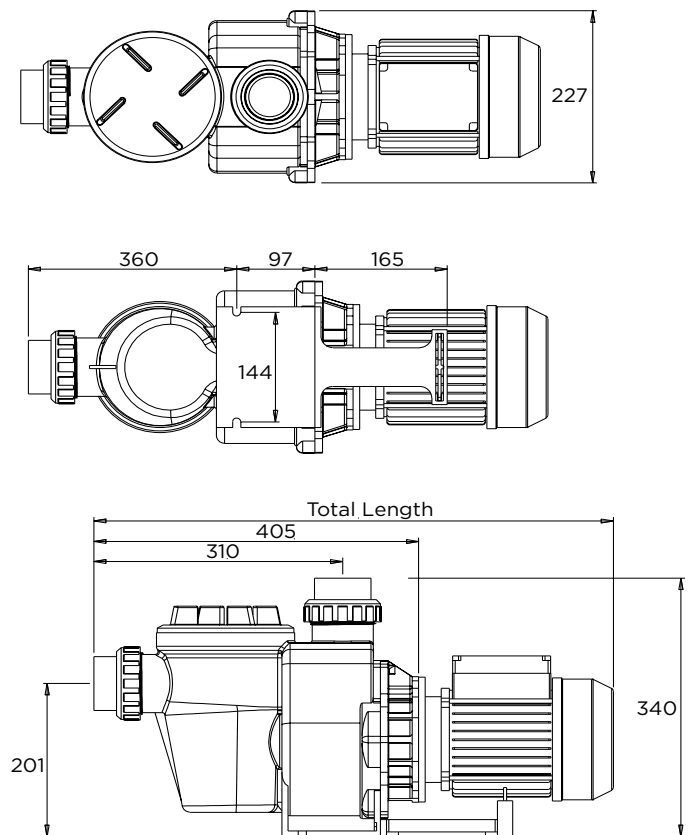

Hydrostorm Sound Levels

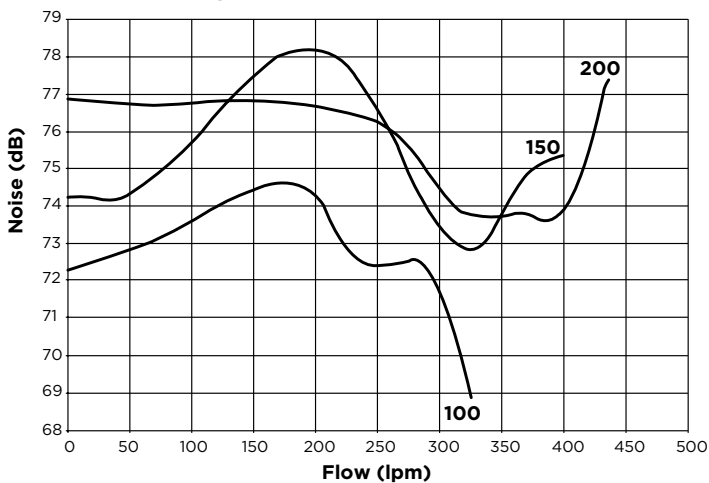

HYDROSTORM PLUS PUMPS



The Hydrostorm plus has all the proven features of the Hydrostorm with the addition of an innovative lid & lock ring for easier maintenance and a larger strainer basket for increased capacity.

Pump	Inlet / outlet	Strainer basket size
Hydrostorm Plus 250	50mm ONLY	1.5L
Hydrostorm Plus 300	65mm ports / 65/50mm unions	1.5L

Technical Specifications

Model	Flow Rate (lpm)		kW	Nominal HP	Amp	Phase	Total Length (mm)
	8m	10m					
Hydrostorm Plus 250	470	440	1.88	2.5	8.2	1	678
Hydrostorm Plus 300	540	500	2.01	3.0	8.8	1	730
Hydrostorm Plus 300	540	500	2.20	3.0	4.1	3	730

Phase	Volts	Cycle	RPM
1	220-240	50	2860

Phase	Volts	Cycle	RPM
3	380-415	50	2800

Please Note:
Hydrostorm Plus 3 phase models are available on request. *15 Amp Power Lead Plug.

Hydrostorm Plus Flow Curves

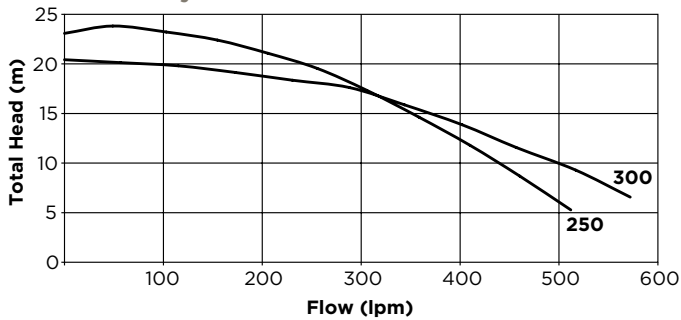

Dimension (mm)

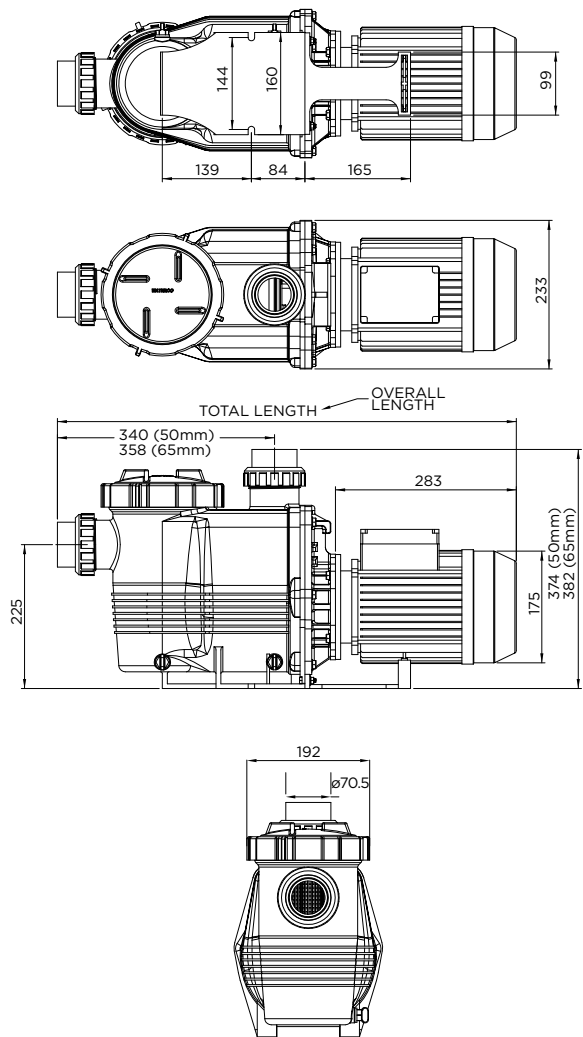

Hydrostorm Plus Sound Levels

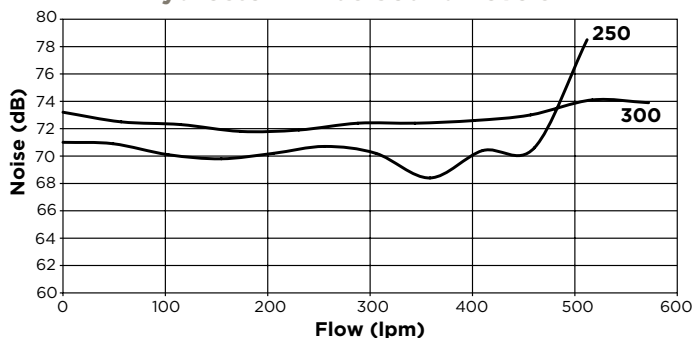

HYDROSTAR PUMPS



Built with an innovative quarter lid & lock ring and extra large strainer basket, the Hydrostar is ideal commercial sized swimming pools.

Technical Specifications

Model	Input Power		Amp/Phase	Weight kg	Total Length mm	Phase	Motor Frame mm	Inlet/Outlet
	kW	HP						
Hydrostar 200	1.52	2.0	3.6	25.0	749	3	80	65mm ports x 50mm unions
Hydrostar 300	2.21	3.0	4.1	29.7	815	3	90	80mm ports x 80mm unions

Phase	Volts	Cycle	Pump Rating
3	380-415	50	IP X5

Hydrostar Plus Flow Curves

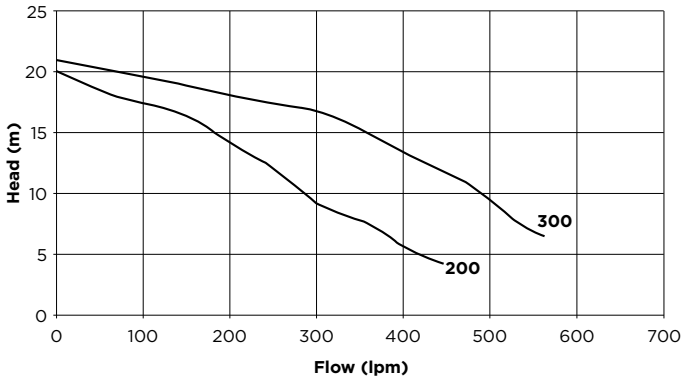

Hydrostar Plus Sound Levels

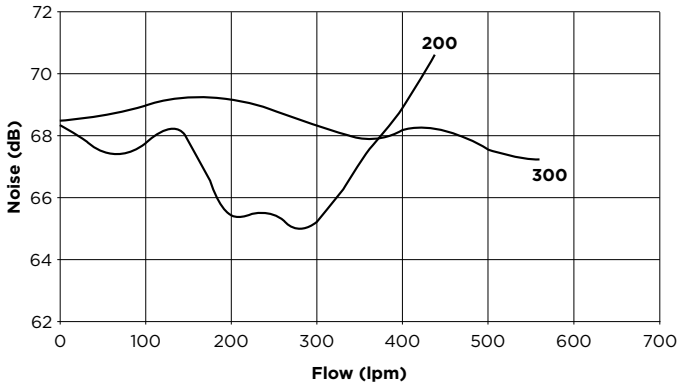

Dimension (mm)

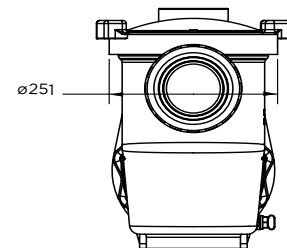
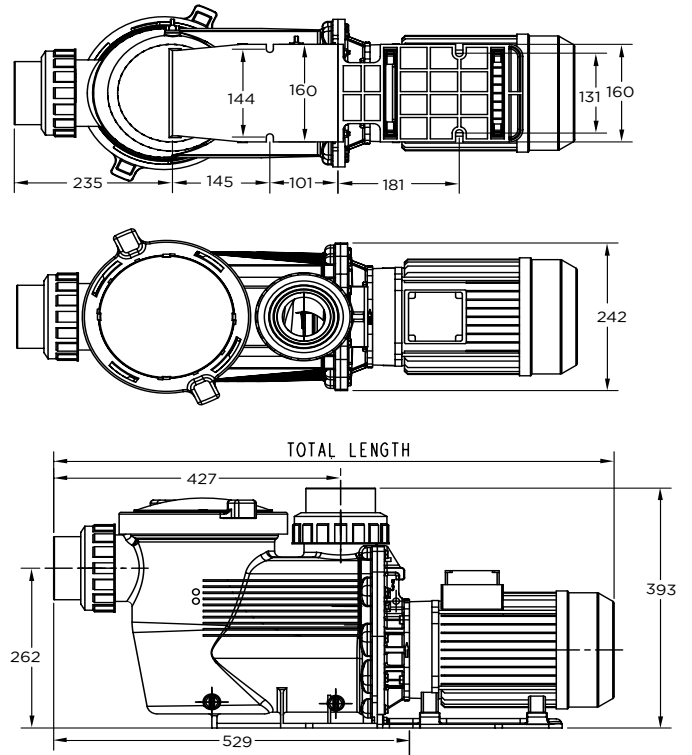

Warranty

Conditions	Warranty Period
Wet End	3 years
Motor, mechanical seal, O' ring, basket & impeller	2 years
Commercial applications	1 year
Labour	1 year

* Please refer to Waterco's warranty terms and conditions

Company Profile

Waterco pioneers reliable solutions for healthy, safe water environments, which are used in residential, commercial and industrial applications in over 40 countries.

Established in 1981 in Sydney, Australia, it has since become a global brand recognised for designing and manufacturing filtration and sanitisation innovations for the swimming pool, spa, aquaculture, and water purification sectors.



CONTACT WATERCO

Waterco's head office is situated in Sydney, Australia with international offices, manufacturing plants and warehouses located in Australia, New Zealand, Malaysia, Indonesia, Singapore, China, the US, Canada, and the UK.

OFFICES - AUSTRALIA

NSW - Sydney (Head Office)
Tel: +61 2 9898 8600
QLD - Brisbane
Tel: +61 7 3299 9900
VIC/TAS - Melbourne
Tel: +61 3 9764 1211
WA - Perth
Tel: +61 8 9273 1900
SA/NT - Adelaide
Tel: +61 8 8244 6000
ACT Distribution
Tel: +61 2 6280 6476

OFFICES - OVERSEAS

Waterco (Europe) Limited
Sittingbourne, Kent, UK
Tel: +44 (0) 1795 521 733
Waterco (USA) Inc
Augusta, Georgia, USA
Tel: +1 706 793 7291
Waterco Canada
Boucherville, Quebec, Canada
Tel: +1 450 748 1421
Waterco (NZ) Limited
Auckland, New Zealand
Tel: +64 9 525 7570

Waterco (C) Limited
Guangzhou, China
Tel: +86 20 3222 2180
Waterco (Far East) Sdn Bhd
Selangor, Malaysia
Tel: +60 3 6145 6000
PT Waterco Indonesia
Jakarta, Indonesia
Tel: +62 21 4585 1481
Waterco Singapore Intl Pte Ltd
Nehsons Building, Singapore
Tel: +65 6344 2378

DISTRIBUTED BY:

